

SERIES 7000 CW

MEDIUM-DUTY ADJUSTABLE
COUNTERWEIGHTED BACKDRAFT DAMPERS

engineering data
and specifications



Medium-Duty Adjustable Counterweighted Backdraft Damper

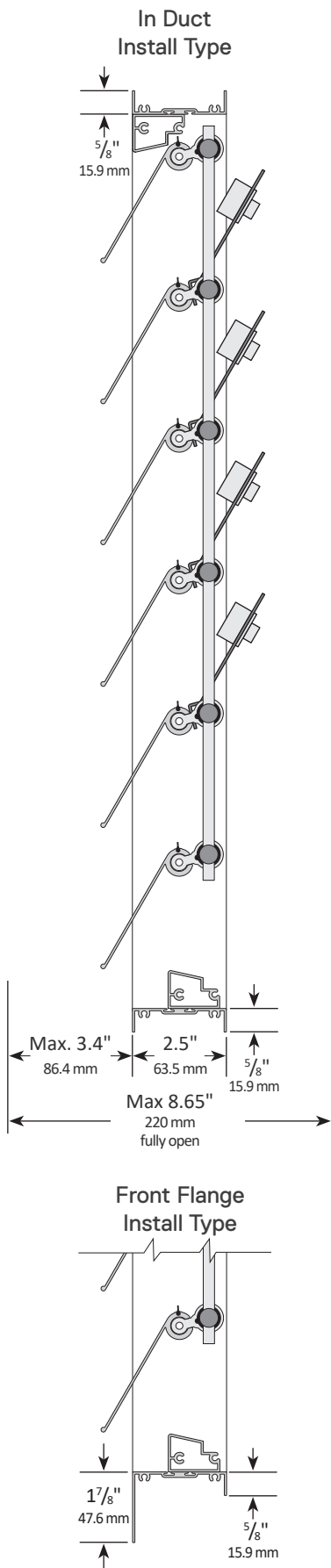

1. Extruded aluminum (6063-T5) counterweighted backdraft damper frame is not less than 0.060" (1.52 mm) in thickness. Frame is 2.5" (63.5 mm) deep x 5/8" (15.9 mm), with mounting flanges on both sides of frame. Frame has a 1 7/8" (47.6 mm) mounting flange on either the front or rear of the damper, when ordered as either Front Flange or Rear Flange install type.
2. Blades are extruded aluminum (6063-T5) profiles not less than 0.060" (1.52 mm) in thickness.
3. Aluminum (6061-T6) counterbalance weights are mounted on each blade. Counterweights are fully adjustable and can be set to relieve air pressure differentials less than .01 in. w.g. (3 Pa). (If increased resistance to the opening of blades against airflow is required, refer to the Series 7000 WT Medium-Duty Adjustable Weighted Backdraft Damper Submittal Data document. The Series 7000 WT is designed to resist opening until a desired static pressure is achieved.)
4. Blade and frame seals are extruded silicone, secured in an integral slot within the aluminum extrusions. Seals are mechanically fastened to prevent shrinkage and movement over the life of the damper.
5. Bearings are composed of 1/2" (12.7 mm) aluminum pivot points, rotating on Celcon bearings.
6. Linkage system consists of hard aluminum alloy (6005-T6) crank arms fastened to aluminum pivot rods and doubly secured within a channel at the top of the blade. Large diameter 1 1/32" (8.73 mm) hard aluminum alloy (6005-T6) linkage rod connects the crank arms by means of a trunnion.
7. Trunnions are zinc-plated steel. These provide a hard, smooth, and long-lasting rotating surface.
8. Cup-point trunnion screw allows for a penetrating grip of the linkage rod. (Cup-point trunnion set screw creates a compression hard spot where it secures to the linkage rod.)
9. Counterweighted backdraft dampers are designed for operation in temperatures ranging from -40°F (-40°C) to 212°F (100°C).
10. Air leakage through a 24" x 24" (610 mm x 610 mm) counterweighted backdraft damper does not exceed 4.32 cfm/ft² (21.95 l/s/m²) against 1 in. w.g. (0.25 kPa) differential static pressure at standard air. Tested in accordance with ANSI/AMCA Standard 500-D.
11. Counterweighted backdraft dampers are custom manufactured to required size, without blanking off free area.
12. Counterweighted backdraft dampers with dimensions greater than maximum section size will be manufactured in multiple sections. (See Install Types page for maximum section dimensions.) Multiple sections are not interlinked or connected. To install, each section must be individually fastened to a structural frame prepared on site. Jumpers and jackshafts are not available for multiple-section counterweighted backdraft dampers.
13. Counterweighted backdraft dampers are available in three install types: Installed In Duct, Rear Flange, or Front Flange. (See Install Types page for details.)
14. Counterweighted backdraft dampers can be mounted for Airflow Up, Airflow Down, or Horizontal Airflow operation.
15. Installation of counterweighted backdraft dampers must be in accordance with TAMCO's current on-line installation guidelines.
16. Intermediate structural support is required to resist applied pressure loads for medium-duty backdraft dampers that consist of two or more sections in both height and width. (See TAMCO Medium-Duty Backdraft Damper Installation Guidelines.)

OPTIONS: For each option listed, replace the lines above with their corresponding lines below.

MR - MOISTURE RESISTANCE OPTION:

1. Extruded aluminum (6063-T5) counterweighted backdraft damper frame is not less than 0.060" (1.52 mm) in thickness. Frame is 2.5" (63.5 mm) deep x 5/8" (15.9 mm), with mounting flanges on both sides of frame. Frame has a 1 7/8" (47.6 mm) mounting flange on either the front or rear of the damper, when ordered as either Front Flange or Rear Flange install type. Frame is assembled using stainless steel screws.
7. Trunnions are stainless steel. They protect against rust in high humidity environments, and provide a hard, smooth, and long-lasting rotating surface.
8. Stainless steel cup-point trunnion screw allows for a penetrating grip of the linkage rod. (Cup-point trunnion set screw creates a compression hard spot where it secures to the linkage rod.)

SW - SALT WATER RESISTANCE OPTION:

1. Extruded aluminum (6063-T5) counterweighted backdraft damper frame is not less than 0.060" (1.52 mm) in thickness. Frame is 2.5" (63.5 mm) deep x 5/8" (15.9 mm), with mounting flanges on both sides of frame. Frame has a 1 7/8" (47.6 mm) mounting flange on either the front or rear of the damper, when ordered as either Front Flange or Rear Flange install type. Aluminum frame is clear anodized to a minimum depth of 0.7 mil (18 microns). Frame is assembled using stainless steel screws.
2. Blades are extruded aluminum (6063-T5) profiles not less than 0.060" (1.52 mm) in thickness, and are clear anodized to a minimum depth of 0.7 mil (18 microns).
6. Linkage system consists of hard aluminum alloy (6005-T6) crank arms fastened to aluminum pivot rods and doubly secured within a channel at the top of the blade. Large diameter 1 1/32" (8.73 mm) hard aluminum alloy (6005-T6) linkage rod connects the crank arms by means of a trunnion. Aluminum linkage components are clear anodized.
7. Trunnions are stainless steel. They protect against rust in high humidity or salt spray environments, and provide a hard, smooth, and long-lasting rotating surface.
8. Stainless steel cup-point trunnion screw allows for a penetrating grip of the linkage rod. (Cup-point trunnion set screw creates a compression hard spot where it secures to the linkage rod.)

VELOCITY VS. PRESSURE DROP

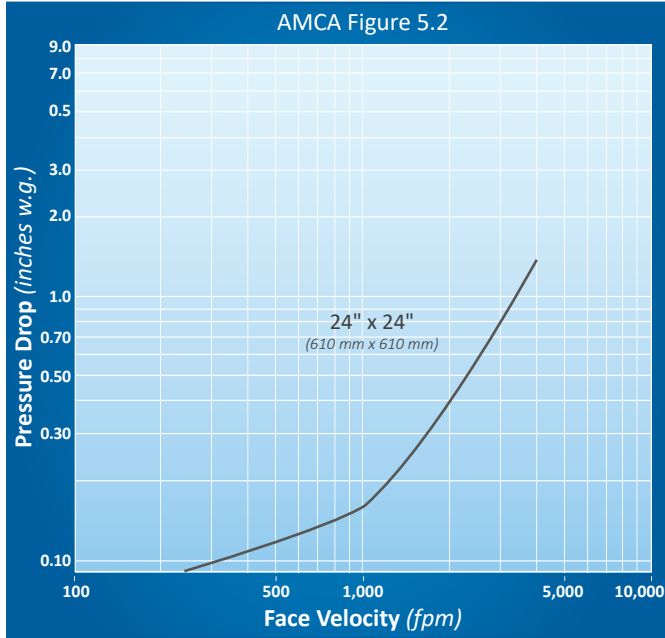

Air Performance testing was conducted in accordance with ANSI/AMCA Standard 500-D, Figure 5.2. Vertically mounted test damper is located at the end of 5 diameters of a duct run, exhausting into an open area. Both duct and test damper are downstream from air supply.

A 24" x 24" (610 mm x 610 mm) TAMCO Series 7000 CW Medium-Duty Adjustable Counterweighted Backdraft Damper was tested.

BLADE DESIGN PRESSURE & VELOCITY LIMITATIONS

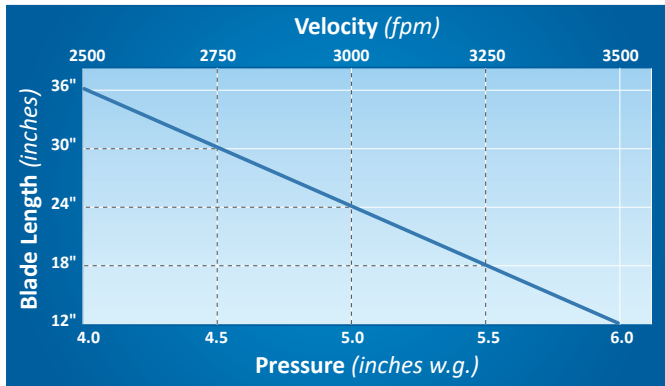

Series 7000 CW Medium-Duty Adjustable Counterweighted Backdraft Dampers that exceed the maximum design pressure or velocity due to blade length may be used by reducing the width of the backdraft damper section(s) and increasing the number of sections to maintain a blade length compatible with the stated system pressure or velocity. Appropriate intermediate structural support will be required for all multiple-section backdraft damper assemblies. (Refer to line 16 of the Submittal Data and to TAMCO's Medium-Duty Backdraft Damper Installation Guidelines.)

Example:

A single section Series 7000 CW Medium-Duty Adjustable Counterweighted Backdraft Damper of 36" w x 36" h (915 mm x 915 mm) at more than 4 in.w.g. (1 kPa) or 2500 fpm (12.7 m/s) would need to be built in two sections of 18" w x 36" h (458 mm x 915 mm).

TAMCO OPERATIONAL DATA

Blades	Velocity		Δ P	
	fpm	(m/s)	in w.g.	(kPa)
Begin to open	6	(0.030)	0.01	(0.003)
Fully open	1800	(9.144)	0.23	(0.057)

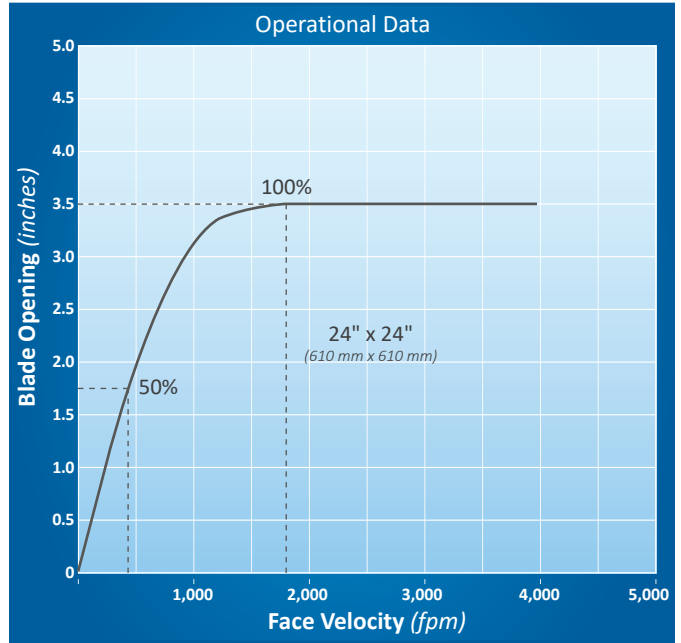

TAMCO LEAKAGE RATES

Static Pressure in w.g.	(kPa)	24" x 24" (610 mm x 610 mm)	
		cfm/ft²	(l/s/m²)
0.5	(0.124)	3.74	(19.00)
1.0	(0.249)	4.32	(21.95)
2.0	(0.498)	5.36	(27.23)
4.0	(1.000)	7.80	(39.62)

Leakage testing was conducted in accordance with ANSI/AMCA Standard 500-D, Figure 5.4. Data are based on a vertically mounted damper, with gravity used as the only closing torque. Air leakage is based on operation between 32°F (0°C) and 120°F (49°C) and converted to standard air density.

A 24" x 24" (610 mm x 610 mm) TAMCO Series 7000 CW Medium-Duty Adjustable Counterweighted Backdraft Damper was tested.

INSTALL TYPES | Series 7000 CW

Medium-Duty Adjustable Counterweighted Backdraft Damper

- Always provide opening width and height dimensions, when ordering.
- Width dimension is always parallel to blades.
- Height dimension is always perpendicular to blades.

INSTALLED IN DUCT TYPE

- Finished damper O.D. is $\frac{1}{4}$ " (6.4 mm) less than opening width and height dimensions.

MINIMUM SECTION SIZE:

12" w x 10" h (305 mm x 254 mm)

MAXIMUM SECTION SIZE:

12.15 ft² (1.2 m²)

36" w x 48.625" h (915 mm x 1235 mm)

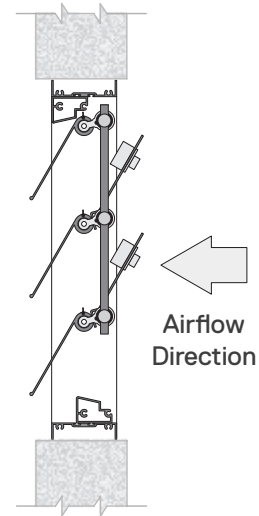

FRONT FLANGE TYPE

- Finished damper O.D. is 2.25" (57.2 mm) greater than opening width and height dimensions.

MINIMUM SECTION SIZE:

12" w x 10" h (305 mm x 254 mm)

MAXIMUM SECTION SIZE:

12.15 ft² (1.2 m²)

36" w x 48.625" h (915 mm x 1235 mm)

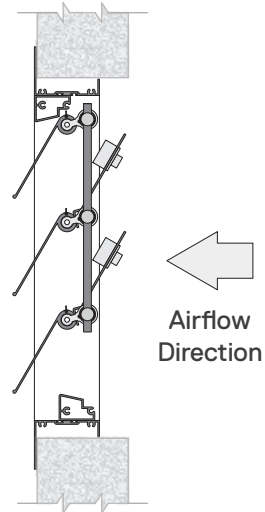

REAR FLANGE TYPE

- Finished damper O.D. is 2.25" (57.2 mm) greater than opening width and height dimensions.

MINIMUM SECTION SIZE:

12" w x 10" h (305 mm x 254 mm)

MAXIMUM SECTION SIZE:

12.15 ft² (1.2 m²)

36" w x 48.625" h (915 mm x 1235 mm)

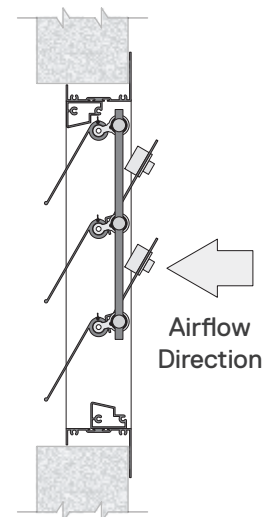

Medium-Duty Adjustable Counterweighted Backdraft Damper

- Always provide airflow direction when ordering.

AIRFLOW DIRECTION

- Series 7000 CW Medium-Duty Adjustable Counterweighted Backdraft Dampers are manufactured for Airflow Up, Airflow Down, and Horizontal Airflow operation.

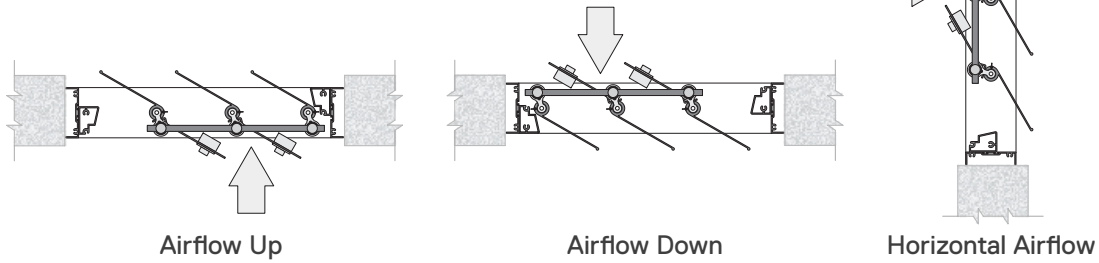

NOTE:

- Suitable for operation in breathable air environments within stated temperature range.
- For Airflow Down mounting, specify TAMCO Series 7000 CW Medium-Duty Adjustable Counterweighted Backdraft Dampers.
- $\frac{1}{4}$ " (6.4 mm) is deducted from the opening dimensions to allow for clearance for all install types.
- The clearance deducted from Front Flange and Rear Flange install types affects the effective flange.

SERIES 7000 CW

ENGINEERING DATA AND SPECIFICATIONS

FOR ADDITIONAL INFORMATION REFER TO:



**SERIES 7000 SUBMITTAL DATA
MEDIUM-DUTY
BACKDRAFT DAMPER**
UNDER THE DOCUMENTS TAB



INSTALLATION GUIDELINES
UNDER THE DOCUMENTS TAB



**SERIES 7000 WT SUBMITTAL DATA
MEDIUM-DUTY ADJUSTABLE
WEIGHTED BACKDRAFT DAMPER**
UNDER THE DOCUMENTS TAB

SPX ENGINEERED AIR MOVEMENT

80 Lorne Street
Smiths Falls, ON K7A 5J7, Canada
800 561 3449
tamcodampers.com

TA-7000CW-TECH-24 | ISSUED 01/2024
© 2024 SPX Engineered Air Movement | All rights reserved
In the interest of technological progress, all products are
subject to design and/or material change without notice.

