

SERIES 7600

HEAVY-DUTY
BACKDRAFT DAMPER

engineering data
and specifications



Heavy-Duty Backdraft Damper

In Duct or Flanged to Duct Install Types

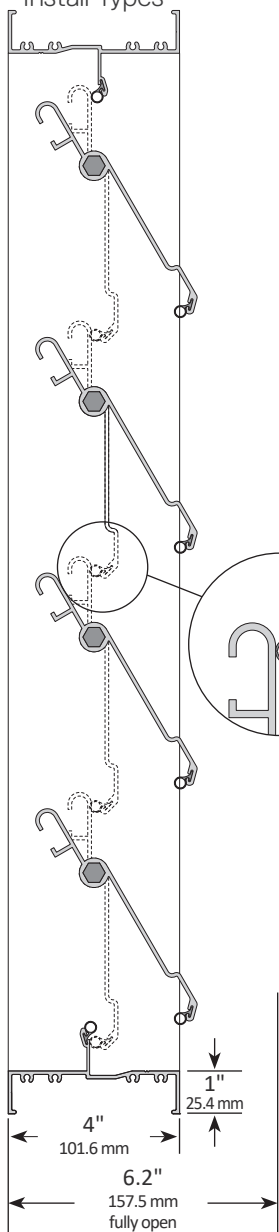

Extended Rear Flange Install Type

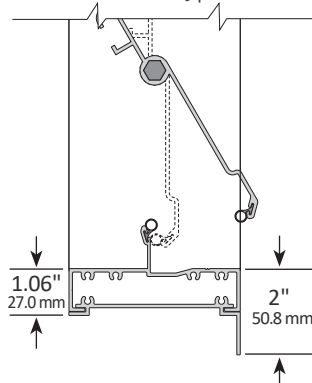

1. Extruded aluminum (6063-T5) heavy-duty backdraft damper frame is not less than 0.080" (2.03 mm) in thickness. Frame is 4" (101.6 mm) deep x 1" (25.4 mm), with mounting flanges on both sides of frame. Frame has a 2" (50.8 mm) mounting flange on either the front or rear of the damper, when ordered as either Extended Front Flange or Extended Rear Flange install type.
2. Blades are extruded aluminum (6063-T5) profiles not less than 0.090" (2.28 mm) in thickness, and are designed with a rounded head to reduce pressure loss.
3. Blade and frame seals are extruded silicone, secured in an integral slot within the aluminum extrusions. Seals are mechanically fastened to prevent shrinkage and movement over the life of the damper.
4. Bearings are composed of a Celcon inner bearing - fixed around a 7/16" (11.11 mm) aluminum hexagon blade pivot pin - rotating within a polycarbonate outer bearing inserted in the frame. This eliminates action between metal-to-metal or metal-to-plastic riding surfaces.
5. Hexagonal 7/16" (11.11 mm) extruded aluminum axles are mechanically fastened to the blade in order to prevent movement and slippage.
6. Aluminum and corrosion-resistant zinc-plated steel linkage hardware is installed in the frame side, complete with cup-point trunnion screws for a slip-proof grip.
7. Heavy-duty backdraft dampers are designed for operation in temperatures ranging from -40°F (-40°C) to 212°F (100°C).
8. Heavy-duty backdraft dampers are custom manufactured to required size, without blanking off free area.
9. Heavy-duty backdraft dampers with dimensions greater than maximum section size will be manufactured in multiple sections. (See Install Types pages for maximum section dimensions.) Jumpers and jackshafts are not available for linking multiple-section backdraft dampers.
10. Heavy-duty backdraft dampers are available in four install types: Installed In Duct, Flanged to Duct, Extended Rear Flange, or Extended Front Flange. (See Install Types pages for details.)
11. Heavy-duty backdraft dampers can be mounted for either Horizontal Airflow or Airflow Up operation.
12. Installation of heavy-duty backdraft dampers must be in accordance with TAMCO's current on-line installation guidelines. (Printed installation guidelines are provided with each damper shipment, however all technical information available on TAMCO's web site at www.tamcodampers.com supersedes information contained within printed versions.)
13. Intermediate structural support is required to resist applied pressure loads for heavy-duty backdraft dampers that consist of two or more sections in both height and width. (See TAMCO Heavy-Duty Backdraft Damper Installation Guidelines.)

OPTIONS: For each option listed, replace the lines above with their corresponding lines below.

ET - ELEVATED TEMPERATURE OPTION:

4. Bearings are composed of a bronze oilite inner bearing - fixed around a 7/16" (11.11 mm) aluminum hexagon blade pivot pin - rotating within a bronze oilite outer bearing inserted in the frame.
6. Aluminum and corrosion-resistant zinc-plated steel linkage hardware is installed in the frame side, complete with cup-point trunnion screws for a slip-proof grip. Trunnion bearing is bronze oilite.
7. Heavy-duty backdraft dampers are designed for operation in temperatures ranging from -40°F (-40°C) to 300°F (149°C).

MR - MOISTURE RESISTANCE OPTION:

1. Extruded aluminum (6063-T5) heavy-duty backdraft damper frame is not less than 0.080" (2.03 mm) in thickness. Frame is 4" (101.6 mm) deep x 1" (25.4 mm), with mounting flanges on both sides of frame. Frame has a 2" (50.8 mm) mounting flange on either the front or rear of the damper, when ordered as either Extended Front Flange or Extended Rear Flange install type. Frame is assembled using stainless steel screws.
6. Aluminum and stainless steel linkage hardware is installed in the frame side, complete with stainless steel cup-point trunnion screws for a slip-proof grip.

SW - SALT WATER RESISTANCE OPTION:

1. Extruded aluminum (6063-T5) heavy-duty backdraft damper frame is not less than 0.080" (2.03 mm) in thickness. Frame is 4" (101.6 mm) deep x 1" (25.4 mm), with mounting flanges on both sides of frame. Frame has a 2" (50.8 mm) mounting flange on either the front or rear of the damper, when ordered as either Extended Front Flange or Extended Rear Flange install type. Aluminum frame is clear anodized to a minimum depth of 0.7 mil (18 microns). Frame is assembled using stainless steel screws.
2. Blades are extruded aluminum (6063-T5) profiles not less than 0.090" (2.28 mm) in thickness, and are designed with a rounded head to reduce pressure loss. Blades are clear anodized to a minimum depth of 0.7 mil (18 microns).
6. Anodized aluminum and stainless steel linkage hardware is installed in the frame side, complete with stainless steel cup-point trunnion screws for a slip-proof grip.

VELOCITY VS. PRESSURE DROP

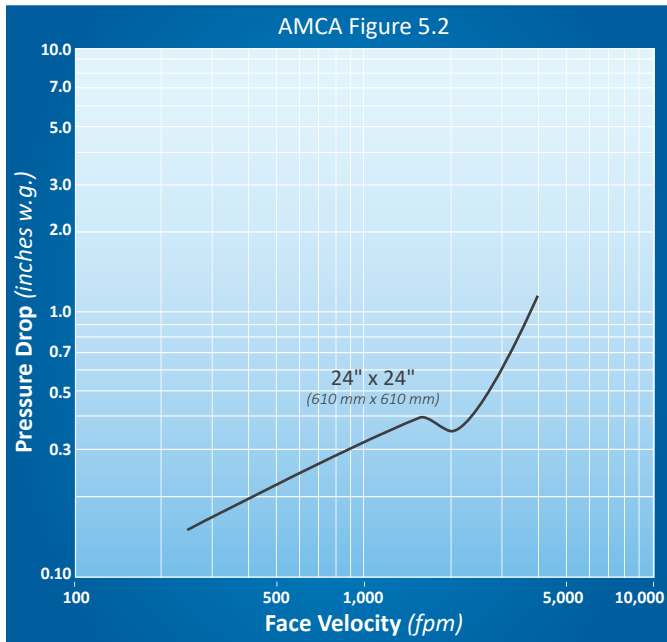

Air Performance testing was conducted in accordance with ANSI/AMCA Standard 500-D, Figure 5.2. Vertically mounted test damper is located at the end of 5 diameters of a duct run, exhausting into an open area. Both duct and test damper are downstream from air supply.

A 24" x 24" (610 mm x 610 mm) TAMCO Series 7600 Heavy-Duty Backdraft Damper was tested.

TAMCO OPERATIONAL DATA

Blades	Velocity		Δ P	
	fpm	(m/s)	in w.g.	(kPa)
Begin to open	20	(0.102)	0.05	(0.012)
Fully open	2260	(11.481)	0.40	(0.100)

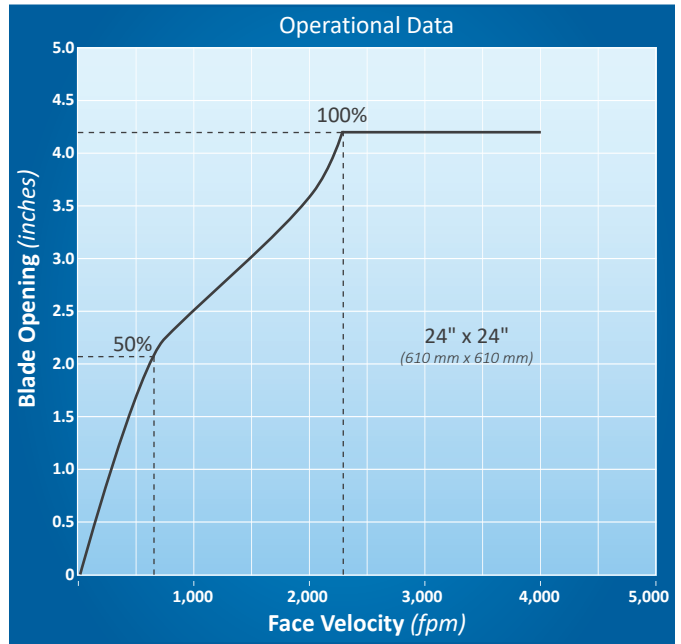

BLADE DESIGN PRESSURE LIMITATIONS

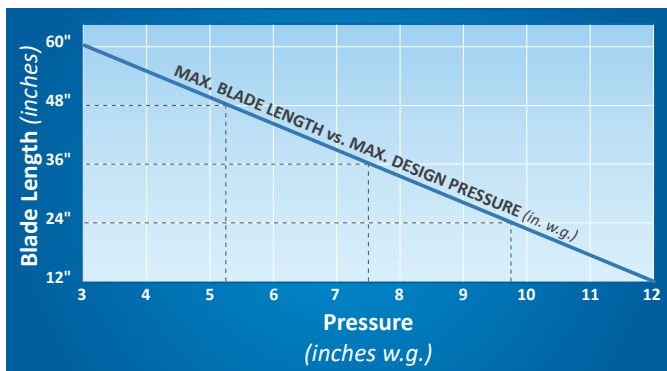

BLADE DESIGN VELOCITY LIMITATIONS

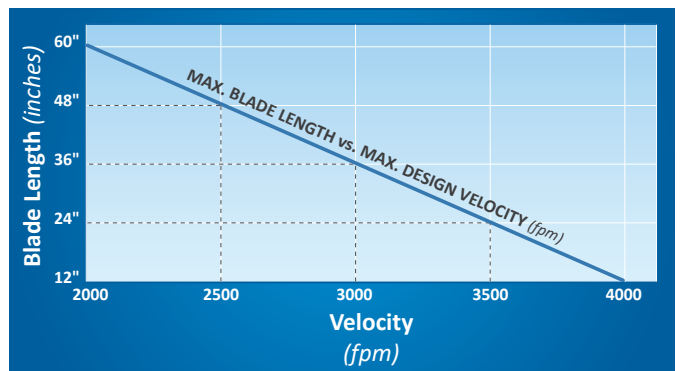

Series 7600 Heavy-Duty Backdraft Dampers that exceed the maximum design pressure or velocity due to blade length may be used by reducing the width of the backdraft damper section(s) and increasing the number of sections to maintain a blade length compatible with the stated system pressure or velocity. Appropriate intermediate structural support will be required for all multiple-section backdraft damper assemblies. (Refer to line 13 of the Submittal Data and to TAMCO's Heavy-Duty Backdraft Damper Installation Guidelines.)

Example:

A single section Series 7600 Heavy-Duty Backdraft Damper of 60"w x 36"h (1524 mm x 915 mm) at more than 7.5 in w.g. (1.87 kPa) would need to be built in two sections of 30"w x 36"h (762 mm x 915 mm).

INSTALL TYPES | Series 7600

Heavy-Duty Backdraft Damper

- Always provide opening width and height dimensions, when ordering.
- Width dimension is always parallel to blades.
- Height dimension is always perpendicular to blades.

INSTALLED IN DUCT TYPE

- Finished damper O.D. is $\frac{1}{2}$ " (12.7 mm) less than opening width and height dimensions.

MINIMUM SECTION SIZE:

6½" w x 6¾" h (166 mm x 172 mm)

MAXIMUM SECTION SIZE:

25 ft² (2.3 m²)

60" w x 60" h or (1524 mm x 1524 mm) or

48" w x 75" h (1220 mm x 1905 mm)



FLANGED TO DUCT TYPE

- Finished damper O.D. is 2" (50.8 mm) greater than opening width and height dimensions.

MINIMUM SECTION SIZE:

4½" w x 4¾" h (115 mm x 108 mm)

MAXIMUM SECTION SIZE:

25 ft² (2.3 m²)

60" w x 60" h or (1524 mm x 1524 mm) or

48" w x 75" h (1220 mm x 1905 mm)

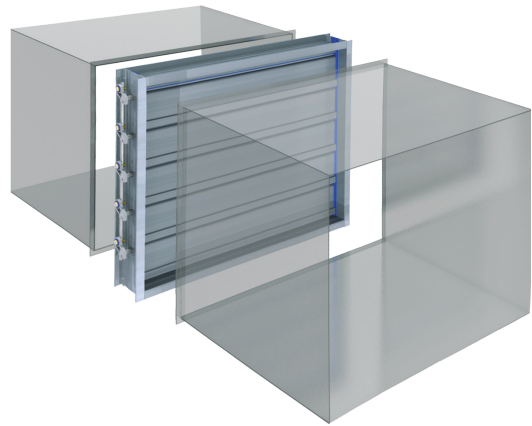

EXTENDED FRONT FLANGE TYPE

- Finished damper O.D. is 4" (101.6 mm) greater than opening width and height dimensions.
- Blades open away from extended flange.

MINIMUM SECTION SIZE:

4½" w x 4¾" h (115 mm x 108 mm)

MAXIMUM SECTION SIZE:

25 ft² (2.3 m²)

60" w x 60" h or (1524 mm x 1524 mm) or

48" w x 75" h (1220 mm x 1905 mm)

- Extended Front Flange install type dampers are not designed so that the back of the damper may be inserted into an opening, as the side frame members extend to the full height of extended flange.



Right linkage side shown

EXTENDED REAR FLANGE TYPE

- Finished damper O.D. is 4" (101.6 mm) greater than opening width and height dimensions.
- Blades open towards extended flange.

MINIMUM SECTION SIZE:

4½" w x 4¾" h (115 mm x 108 mm)

MAXIMUM SECTION SIZE:

25 ft² (2.3 m²)

60" w x 60" h or (1524 mm x 1524 mm) or

48" w x 75" h (1220 mm x 1905 mm)

- Extended Rear Flange install type dampers are not designed so that the front of the damper may be inserted into an opening, as the side frame members extend to the full height of the rear flange.

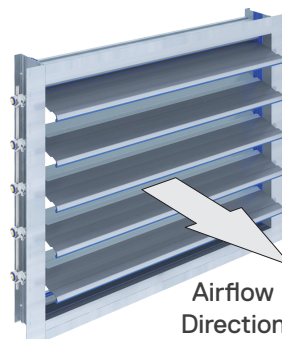

Heavy-Duty Backdraft Damper

- Always provide airflow direction when ordering.

AIRFLOW DIRECTION

- Series 7600 Heavy-Duty Backdraft Dampers are manufactured for Airflow Up and Horizontal Airflow operation.

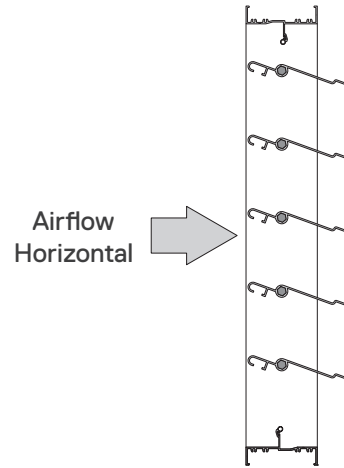
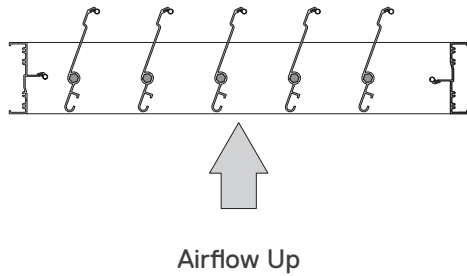

LINKAGE SIDE

LEFT LINKAGE

- When viewing the damper from the sticker side, the linkage will be on the left. The sticker is applied to the upstream side of the damper.



Extended Rear Flange install type shown.

RIGHT LINKAGE

- When viewing the damper from the sticker side, the linkage will be on the right. The sticker is applied to the upstream side of the damper.



Extended Rear Flange install type shown.

NOTE:

- To reduce pressure drop, use Flanged to Duct mount type for sizes under 9 ft² (.83 m²).
- Suitable for operation in breathable air environments within stated temperature range.
- For Airflow Down mounting, specify TAMCO Series 7600 CWA Counterweighted Heavy-Duty Backdraft Dampers.

SERIES 7600

ENGINEERING DATA AND SPECIFICATIONS

FOR ADDITIONAL INFORMATION REFER TO:



**SERIES 7600 CW SUBMITTAL DATA
INTERNALLY COUNTERWEIGHTED
HEAVY-DUTY BACKDRAFT DAMPER
UNDER THE DOCUMENTS TAB**



**SERIES 7600 WT SUBMITTAL DATA
ADJUSTABLE WEIGHTED
HEAVY-DUTY BACKDRAFT DAMPER
UNDER THE DOCUMENTS TAB**



**SERIES 7600 CWA SUBMITTAL DATA
ADJUSTABLE COUNTERWEIGHTED
HEAVY-DUTY BACKDRAFT DAMPER
UNDER THE DOCUMENTS TAB**



**INSTALLATION GUIDELINES
UNDER THE DOCUMENTS TAB:**

SPX ENGINEERED AIR MOVEMENT

80 Lorne Street
Smiths Falls, ON K7A 5J7, Canada
800 561 3449
tamcodampers.com

TA-7600-TECH-24 | ISSUED 01/2024
© 2024 SPX Engineered Air Movement | All rights reserved
In the interest of technological progress, all products are
subject to design and/or material change without notice.

