

# SERIES 8800

HEAVY-DUTY  
AIR-FOIL CONTROL DAMPERS

engineering data  
and specifications



**TAMCO** 

**PARALLEL ACTION**

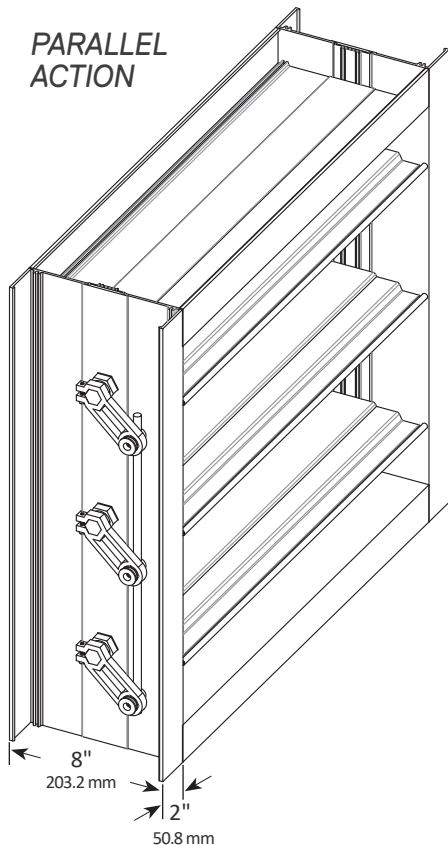

**OPPOSED ACTION**

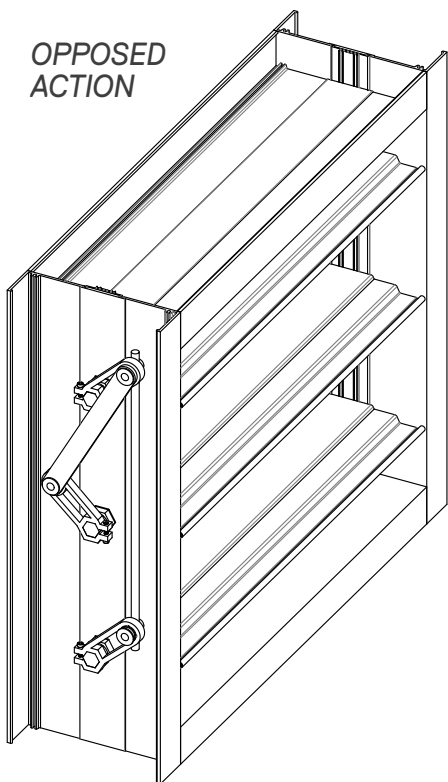

1. Extruded, mill-finish aluminum (6063-T5) damper frame is not less than 0.125" (3.17 mm) in thickness. Damper frame is 8" (203.2 mm) deep x 2" (50.8 mm), with mounting flanges on both sides of the frame.
2. Blades are maximum 8" (203.2 mm) deep extruded aluminum (6063-T5) air-foil profiles and are not less than 0.081" (2.1 mm) in thickness.
3. Blade and frame seals are extruded silicone. Seals are secured in an integral slot within the aluminum extrusions. Blade and frame seals are mechanically fastened to prevent shrinkage and movement over the life of the damper.
4. Bearings are composed of a bronze oilite inner bearing - fixed around a 3/4" (19.05 mm) aluminum hexagon blade pivot pin - rotating within a bronze oilite outer bearing inserted in the frame.
5. A fixed 3/4" (19.05 mm) aluminum hexagonal drive rod will be staked at a measurement of 6" (152.4 mm) extending beyond the edge of the damper frame.
6. Mill-finish aluminum and corrosion-resistant zinc-plated steel linkage hardware is installed in the frame side, complete with cup-point set screws for a slip-proof grip. Trunnion bearing is bronze oilite.
7. Dampers are designed for operation in temperatures ranging from -40°F (-40°C) to 300°F (149°C).
8. Leakage for a 24" x 24" (610 mm x 610 mm) damper does not exceed 3.9 cfm/ft<sup>2</sup> (19.8 l/s/m<sup>2</sup>) against 1 in w.g. (0.25 kPa) differential static pressure. Tested in accordance with ANSI/AMCA Standard 500-D.
9. Dampers are custom made to required size, without blanking off free area. Specifically engineered blade stops are located outside the air stream, providing a larger free area and reduced pressure drop. The blade stops are a continuous and integral part of the top and bottom frames.
10. Dampers are available with either opposed blade action or parallel blade action.
11. Dampers are available in Flanged to Duct install type only.
12. Installation of heavy-duty dampers must be in accordance with TAMCO's current on-line installation guidelines. (Printed installation guidelines are provided with each damper shipment, however all technical information available on TAMCO's web site at [www.tamcodampers.com](http://www.tamcodampers.com) supersedes information contained within printed versions.)
13. Intermediate structural support is required to resist applied pressure loads for heavy-duty dampers that consist of two or more sections in both height and width. (See TAMCO Heavy-Duty Control Damper Installation Guidelines.)

**OPTIONS:** For each option listed, replace the lines above with their corresponding lines below.

**MR - MOISTURE RESISTANCE OPTION:**

1. Extruded, mill-finish aluminum (6063-T5) damper frame is not less than 0.125" (3.17 mm) in thickness. Damper frame is 8" (203.2 mm) deep x 2" (50.8 mm), with mounting flanges on both sides of frame. Frame is assembled using stainless steel screws.
6. Mill-finish aluminum and stainless steel linkage hardware is installed in the frame side, complete with stainless steel cup-point set screws for a slip-proof grip. Trunnion bearing is bronze oilite.

**SW - SALT WATER RESISTANCE OPTION:**

1. Extruded aluminum (6063-T5) damper frame is not less than 0.125" (3.17 mm) in thickness. Damper frame is 8" (203.2 mm) deep x 2" (50.8 mm), with mounting flanges on both sides of frame. Aluminum frame is clear anodized to a minimum depth of 0.7 mil (18 microns). Frame is assembled using stainless steel screws.
2. Blades are maximum 8" (203.2 mm) deep extruded aluminum (6063-T5) air-foil profiles and are not less than 0.081" (2.1 mm) in thickness. Extruded aluminum blades are clear anodized to a minimum depth of 0.7 mil (18 microns).
6. Clear anodized aluminum and stainless steel linkage hardware is installed in the frame side, complete with stainless steel cup-point trunnion screws for a slip-proof grip. Trunnion bearing is bronze oilite.

**OPTIONAL PAINT OR COATING FINISHES:**

Contact TAMCO Customer Service for more information regarding paint or coating finishes.

USA Patent number 10,222,089

VELOCITY VS. PRESSURE DROP

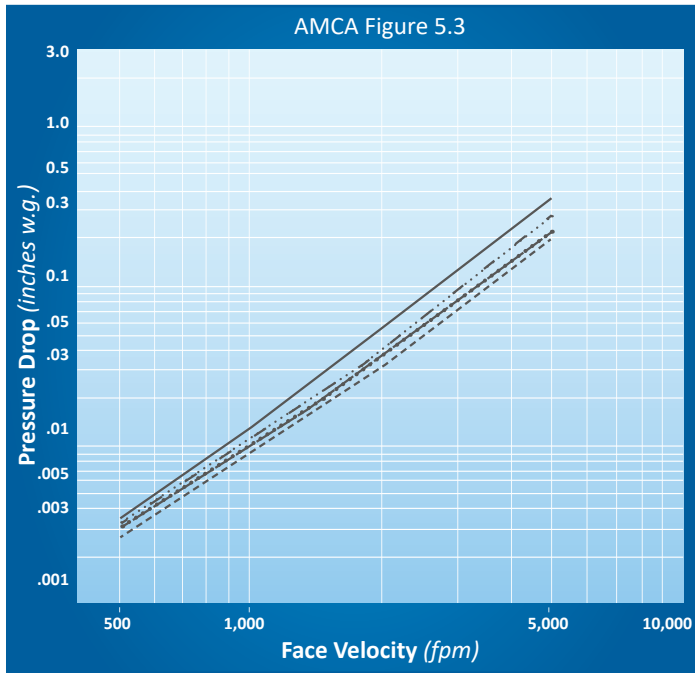

- Specifically engineered blade stops are located outside the air stream, providing a larger free area and reduced pressure drop.

Air Performance testing was conducted in accordance with ANSI/AMCA Standard 500-D, Figure 5.3. Test damper is fully ducted with a 5 diameter duct run upstream, and a 6 diameter duct run downstream.

**LEGEND:**

<b>12" x 12"</b> (305 mm x 305 mm) ———	<b>24" x 24"</b> (610 mm x 610 mm) - - - -	<b>48" x 12"</b> (1220 mm x 305 mm) - · - · -
<b>12" x 48"</b> (305 mm x 1220 mm) — · —	<b>36" x 36"</b> (915 mm x 915 mm) · · · · ·	

Damper Width inches (mm)	LEAKAGE ft <sup>3</sup> /min/ft <sup>2</sup> (l/s/m <sup>2</sup> )					
	1 in. w.g. 0.25 kPa	4 in. w.g. 1.0 kPa	8 in. w.g. 2.0 kPa	12 in. w.g. 3.0 kPa	16 in. w.g. 4.0 kPa	20 in. w.g. 5.0 kPa
0.0 to 24.0 (0 - 610)	3.9 (19.8)	5.7 (29.0)	7.1 (36.1)	8.1 (41.1)	9.0 (45.7)	10.1 (51.3)
24.1 to 36.0 (611 - 915)	3.3 (16.8)	4.1 (20.8)	4.7 (23.9)	5.1 (25.9)	5.3 (26.9)	5.5 (27.9)
36.1 to 48.0 (916 - 1220)	2.6 (13.2)	3.6 (18.3)	4.3 (21.9)	5.1 (25.9)	*	*
48.1 to 60.0 (1221 - 1524)	2.2 (11.2)	3.0 (15.2)	5.3 (26.9)	*	*	*

Leakage testing was conducted in accordance with ANSI/AMCA Standard 500-D, Figure 5.4. Data are based on a torque of 8 in-lb/ft<sup>2</sup> (9.72 N-m/m<sup>2</sup>) with a minimum of 60 in-lb (72.97 N-m/m<sup>2</sup>) applied to close and seat the parallel blade damper during the test. Air leakage is based on operation between 32°F (0°C) and 120°F (49°C).

The following sizes of TAMCO Series 8800 dampers were tested: 24" x 24" (610 mm x 610 mm), 36" x 36" (915 mm x 915 mm), 48" x 36" (1220 mm x 915 mm), 60" x 36" (1524 mm x 915 mm).

**\* NOTE:** TAMCO Leakage is not provided for these categories as the recommended blade length is exceeded at these static pressures.  
(Refer to the Blade Design Pressure Limitations Chart.)

**BLADE DESIGN PRESSURE LIMITATIONS**

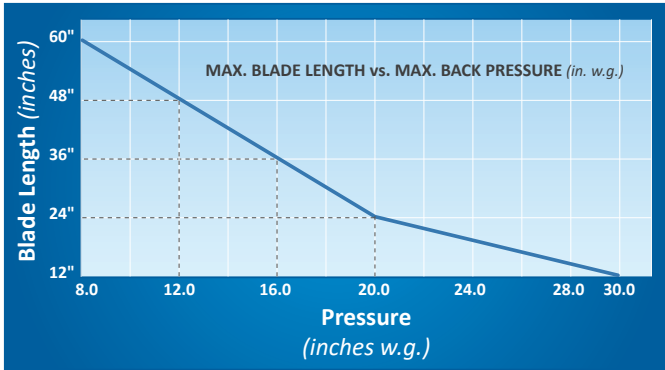

**BLADE DESIGN VELOCITY LIMITATIONS**

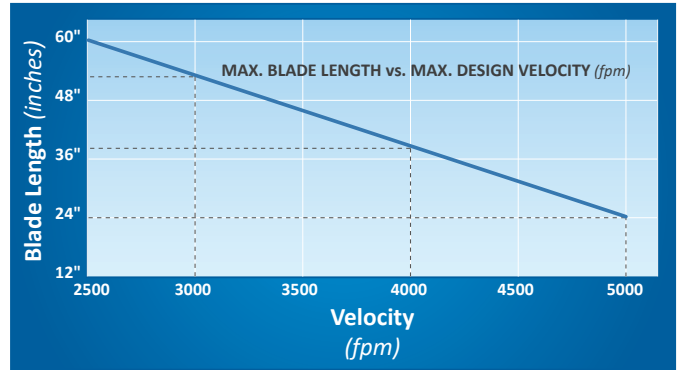

Series 8800 Heavy-Duty Dampers, whose blade length exceeds the maximum design pressure or design velocity, February be reconfigured to maintain a blade length compatible with the required system pressure or velocity by increasing the number of sections per damper and thereby reducing each damper section’s blade length. Appropriate intermediate structural support will be required for all multiple-section damper assemblies. (Refer to line 13 of the Submittal Data and to TAMCO’s Heavy-Duty Control Damper Installation Guidelines.)

**Example:**

A single-section damper of 60”w x 36”h (1524 mm x 915 mm) at more 8 in w.g. (2 kPa) would need to be built in 2 sections of 30”w x 36”h (762 mm x 915 mm).

**INSTALL TYPE**

- Always provide opening width and height dimensions, when ordering.
- Width dimension is always parallel to blades.
- Height dimension is always perpendicular to blades.

**FLANGED TO DUCT TYPE**

- Finished damper O.D. is 4” (101.6 mm) greater than opening width and height dimensions.

**MAXIMUM SECTION SIZE:**

60”w x 96”h or (1524 mm x 2439 mm) or  
40 ft<sup>2</sup> (3.7 m<sup>2</sup>)

- Dampers exceeding the maximum section size, will be built in multiple sections.
- Multiple sections cannot be linked and each section must be operated independently.

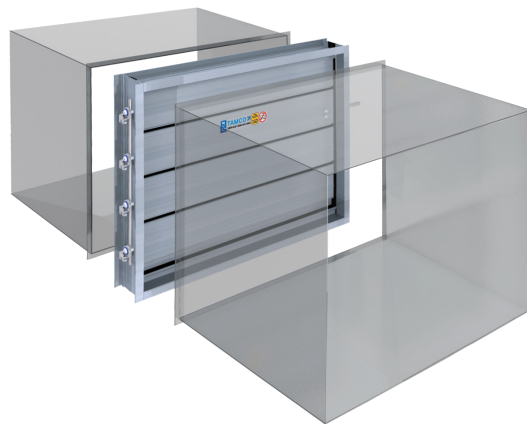

**NOTE:**

- Suitable for operation in breathable air environments within stated temperature range.

FOR ADDITIONAL INFORMATION REFER TO:



HEAVY-DUTY CONTROL DAMPER  
INSTALLATION GUIDELINES  
UNDER THE DOCUMENTS TAB



INSTALLATION GUIDELINE  
VIDEOS

# SERIES 8800

ENGINEERING DATA AND SPECIFICATIONS

## SPX ENGINEERED AIR MOVEMENT

80 Lorne Street  
Smiths Falls, ON K7A 5J7, Canada  
800 561 3449  
[tamcodampers.com](http://tamcodampers.com)

TA-8800-TECH-24 | ISSUED 01/2024  
© 2024 SPX Engineered Air Movement | All rights reserved  
In the interest of technological progress, all products are  
subject to design and/or material change without notice.

