

SERIES 9000

THERMALLY INSULATED DAMPER
WITH THERMALLY BROKEN BLADES

engineering data
and specifications

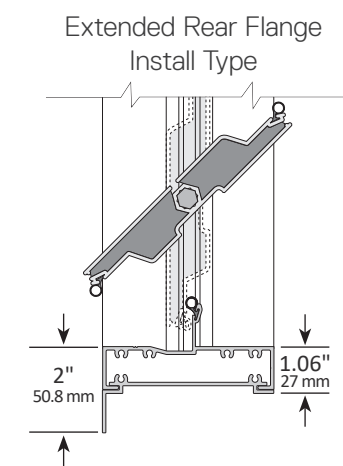

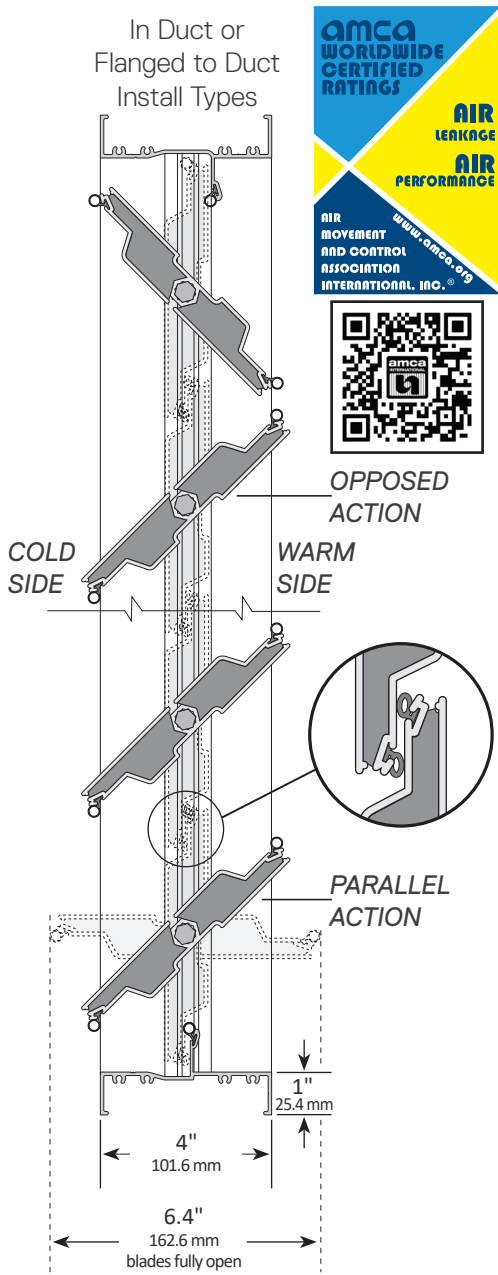

1. Extruded aluminum (6063-T5) damper frame is not less than 0.080" (2.03 mm) in thickness. Damper frame is 4" (101.6 mm) deep x 1" (25.4 mm), with mounting flanges on both sides of frame. Damper frame has a 2" (50.8 mm) mounting flange on the rear of the damper, when ordered as Extended Rear Flange install type.
2. Blades are maximum 6" (152.4 mm) deep extruded aluminum (6063-T5) air-foil profiles, internally insulated with expanded polyurethane foam and thermally broken. Complete blade has an insulating factor of R-2.29. All blades are symmetrically pivoted.
3. Blade seals are extruded EPDM. Frame seals are extruded silicone. Seals are secured in an integral slot within the aluminum extrusions. Blade and frame seals are mechanically fastened to prevent shrinkage and movement over the life of the damper.
4. Bearings are composed of a Celcon inner bearing - fixed around a 7/16" (11.11 mm) aluminum hexagon blade pivot pin - rotating within a polycarbonate outer bearing inserted in the frame. This eliminates action between metal-to-metal or metal-to-plastic riding surfaces.
5. Adjustable 7/16" (11.11 mm) hexagonal drive rod, U-bolt fastener, and hexagonal retaining nuts are zinc-plated steel. These provide a positive connection to blades and linkage.
6. Aluminum and corrosion-resistant zinc-plated steel linkage hardware is installed in the frame side, complete with cup-point trunnion screws for a slip-proof grip.
7. Dampers are designed for operation in temperatures ranging from -40 °F (-40 °C) to 212 °F (100 °C).
8. Leakage Class 1A at 1 in. w.g. (0.25 kPa) static pressure differential. Standard air leakage data is certified under the AMCA Certified Ratings Program.
9. Dampers are custom made to required size, without blanking off free area. The blade stop is set at a fixed height and is a continuous and integral part of the top and bottom frames.
10. Dampers are available with either opposed blade action or parallel blade action.
11. Dampers are available in four install types: Installed In Duct, Flanged to Duct, Extended Rear Flange, and Square to Round Transition. (See Install Type pages for details.)
12. Installation of dampers must be in accordance with TAMCO's current on-line installation guidelines. (Printed installation guidelines are provided with each damper shipment, however all technical information available on TAMCO's web site at www.tamcodampers.com supersedes information contained within printed versions.)
13. Intermediate structural support is required to resist applied pressure loads for dampers that consist of two or more sections in both height and width. (See TAMCO Aluminum Damper Installation Guidelines.)

OPTIONS FOR SP – STANDARD PROFILE:

For each option listed, replace the lines above with their corresponding lines below.

SC - SEVERE COLD TEMPERATURE OPTION:

3. Blade and frame seals are extruded silicone, for reduced air leakage at colder temperatures. Blade and frame seals are secured in an integral slot within the aluminum extrusions and are mechanically fastened to prevent shrinkage and movement over the life of the damper.

MR - MOISTURE RESISTANCE OPTION:

1. Extruded aluminum (6063-T5) damper frame is not less than 0.080" (2.03 mm) in thickness. Damper frame is 4" (101.6 mm) deep x 1" (25.4 mm), with mounting flanges on both sides of frame. Damper frame has a 2" (50.8 mm) mounting flange on the rear of the damper, when ordered as Extended Rear Flange install type. Frame is assembled using stainless steel screws.
5. Adjustable 7/16" (11.11 mm) hexagonal drive rod, U-bolt fastener, and hexagonal retaining nuts are stainless steel. These provide a positive connection to blades and linkage.
6. Aluminum and stainless steel linkage hardware is installed in the frame side, complete with stainless steel cup-point trunnion screws for a slip-proof grip.

SW - SALT WATER RESISTANCE OPTION:

1. Extruded aluminum (6063-T5) damper frame is not less than 0.080" (2.03 mm) in thickness. Damper frame is 4" (101.6 mm) deep x 1" (25.4 mm), with mounting flanges on both sides of frame. Damper frame has a 2" (50.8 mm) mounting flange on the rear of the damper, when ordered as Extended Rear Flange install type. Aluminum frame is clear anodized to a minimum depth of 0.7 mil (18 microns). Frame is assembled using stainless steel screws.
2. Blades are maximum 6" (152.4 mm) deep extruded aluminum (6063-T5) air-foil profiles, internally insulated with expanded polyurethane foam and thermally broken. Complete blade has an insulating factor of R-2.29. All blades are symmetrically pivoted. Extruded aluminum blades are clear anodized to a minimum depth of 0.7 mil (18 microns).
3. Blade and frame seals are extruded silicone, for reduced air leakage at colder temperatures. Blade and frame seals are secured in an integral slot within the aluminum extrusions and are mechanically fastened to prevent shrinkage and movement over the life of the damper.
5. Adjustable 7/16" (11.11 mm) hexagonal drive rod, U-bolt fastener, and hexagonal retaining nuts are stainless steel. These provide a positive connection to blades and linkage.
6. Clear anodized aluminum and stainless steel linkage hardware is installed in the frame side, complete with stainless steel cup-point trunnion screws for a slip-proof grip.

PERFORMANCE DATA | Series 9000 Thermally Insulated Damper with Thermally Broken Blades

SP – Standard Profile

With no Option or with MR Option

VELOCITY VS. PRESSURE DROP

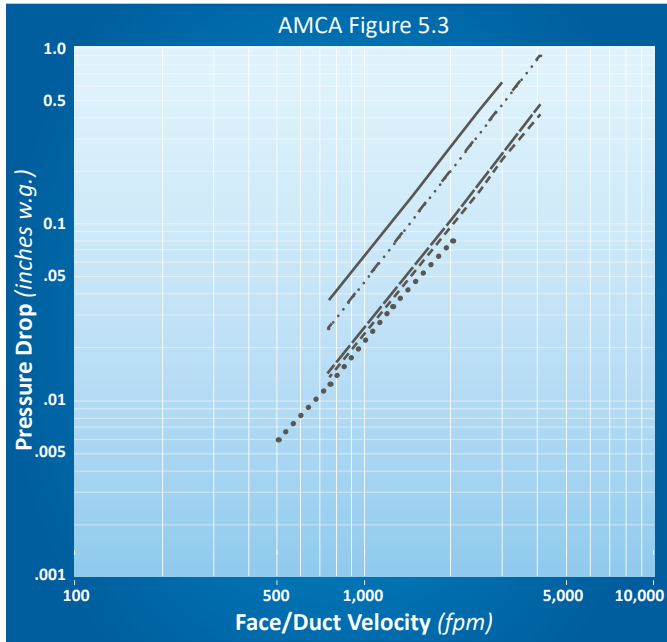

LEGEND:

12" x 12" ——— (305 mm x 305 mm)	24" x 24" - - - - (610 mm x 610 mm)	48" x 12" - · - · - (1220 mm x 305 mm)
12" x 48" ——— (305 mm x 1220 mm)	36" x 36" · · · · (915 mm x 915 mm)	

BLADE DESIGN PRESSURE LIMITATIONS

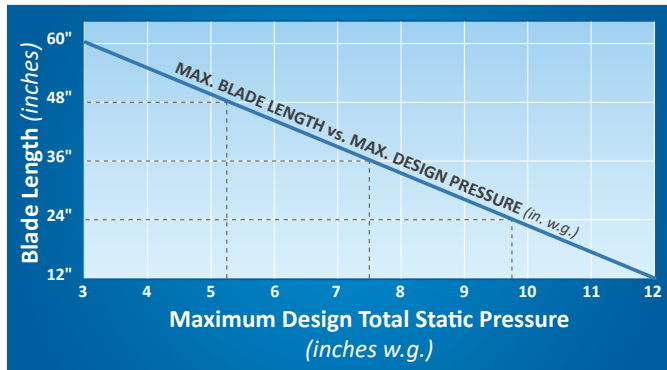

Series 9000 dampers with SP – Standard Profile, whose blade length exceeds the maximum design pressure, may be reconfigured to maintain a blade length compatible with the required system pressure by increasing the number of sections per damper and thereby reducing each damper section's blade length. Appropriate intermediate structural support will be required for all multiple-section damper assemblies. (Refer to line 13 of the Submittal Data and to TAMCO's Aluminum Damper Installation Guidelines.)

Example:

A single-section damper of 60" w x 36" h (1524 mm x 915 mm) at 5 in w.g. (1.24 kPa) would need to be built in two sections of 30" w x 36" h (762 mm x 915 mm).

T.A. Morrison & Co. Inc. certifies that the TAMCO Series 9000 Thermally Insulated Damper, with Thermally Broken Blades, no Option or MR Options, and SP – Standard Profile shown herein is licensed to bear the AMCA Seal. The ratings shown are based on tests and procedures performed in accordance with AMCA Publication 511 and comply with the requirements of the AMCA Certified Ratings Program. The AMCA Certified Ratings Seal applies to air leakage and air performance ratings.



FIG. 5.3 Test damper is fully ducted with a 5 diameter duct run upstream, and a 6 diameter duct run downstream.

Pressure drop values are based on Flanged to Duct install type. Pressure drop will be greater for In Duct install type dampers.

TAMCO LEAKAGE RATING

Damper Width inches (mm)	1 in. w.g. 0.25 kPa	4 in. w.g. 1.0 kPa
0.0 to 12.0 (0 to 305)	1A	1
12.1 to 36.0 (306 to 915)	1A	1
36.1 to 48.0 (916 to 1220)	1A	1
48.1 to 60.0 (1221 to 1524)	1A	1

Leakage testing was conducted in accordance with ANSI/AMCA Standard 500-D, Figure 5.4. Data are based on a torque of 10.8 in-lb/ft² (13.1 N-m/m²) and a minimum of 70 in-lb (7.9 N-m) applied to close and seat the opposed blade damper during the test. Air leakage is based on operation between 32 °F (0 °C) and 120 °F (49 °C).

The following sizes of TAMCO Series 9000 dampers with no Option or MR Option, and SP – Standard Profile were tested:

12" x 48" (305 mm x 1220 mm), 36" x 36" (915 mm x 915 mm), 48" x 36" (1220 mm x 915mm), 60" x 36" (1524 mm x 915 mm).

AMCA LEAKAGE CLASS DEFINITIONS

Pressure Class	MAXIMUM ALLOWABLE LEAKAGE CFM/ft ² (l/s/m ²)	
	1 in. w.g. 0.25 kPa	4 in. w.g. 1.0 kPa
1A	3 (15.2)	n/a
1	4 (20.3)	8 (40.6)
2	10 (50.8)	20 (102)
3	40 (203)	80 (406)

PERFORMANCE DATA | Series 9000 Thermally Insulated Damper with Thermally Broken Blades

SP – Standard Profile
With SC Option or SW Option

VELOCITY VS. PRESSURE DROP

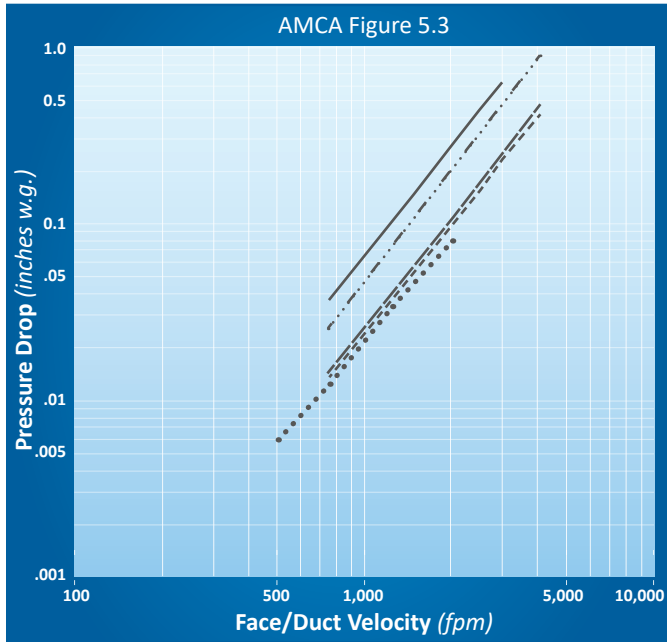

LEGEND:

12" x 12" ——— (305 mm x 305 mm)	24" x 24" ---- (610 mm x 610 mm)	48" x 12" - - - - (1220 mm x 305 mm)
12" x 48" ——— (305 mm x 1220 mm)	36" x 36" ····· (915 mm x 915 mm)	

BLADE DESIGN PRESSURE LIMITATIONS

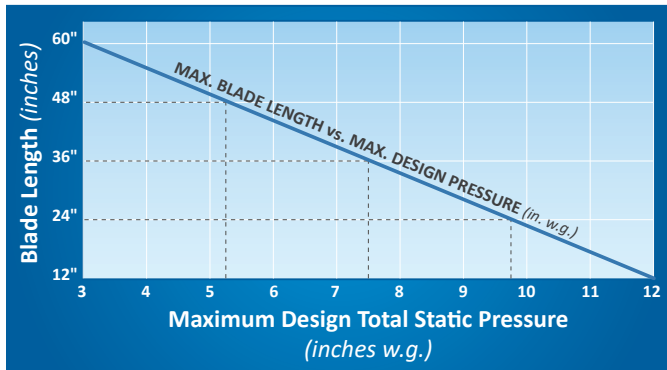

Series 9000 dampers with SP – Standard Profile, whose blade length exceeds the maximum design pressure, may be reconfigured to maintain a blade length compatible with the required system pressure by increasing the number of sections per damper and thereby reducing each damper section's blade length. Appropriate intermediate structural support will be required for all multiple-section damper assemblies. (Refer to line 13 of the Submittal Data and to TAMCO's Aluminum Damper Installation Guidelines.)

Example:

A single-section damper of 60" w x 36" h (1524 mm x 915 mm) at 5 in. w.g. (1.24 kPa) would need to be built in two sections of 30" w x 36" h (762 mm x 915 mm).

T.A. Morrison & Co. Inc. certifies that the TAMCO Series 9000 Thermally Insulated Damper, with Thermally Broken Blades, SC or SW Options, and SP – Standard Profile shown herein is licensed to bear the AMCA Seal. The ratings shown are based on tests and procedures performed in accordance with AMCA Publication 511 and comply with the requirements of the AMCA Certified Ratings Program. The AMCA Certified Ratings Seal applies to air leakage and air performance ratings.



FIG. 5.3 Test damper is fully ducted with a 5 diameter duct run upstream, and a 6 diameter duct run downstream.

Pressure drop values are based on Flanged to Duct install type. Pressure drop will be greater for In Duct install type dampers.

TAMCO LEAKAGE RATING

Damper Width inches (mm)	1 in. w.g. 0.25 kPa	4 in. w.g. 1.0 kPa	6 in. w.g. 1.5 kPa	8 in. w.g. 2.0 kPa
0.0 to 12.0 (0 to 305)	1A	1	1	1
12.1 to 36.0 (306 to 915)	1A	1	1	1
36.1 to 48.0 (916 to 1220)	1A	1	1	1
48.1 to 60.0 (1221 to 1524)	1A	1	n/a	n/a

Leakage testing was conducted in accordance with ANSI/AMCA Standard 500-D, Figure 5.4. Data are based on a torque of 10.8 in-lb/ft² (13.1 N-m/m²) applied to close and seat the opposed blade damper during the test. Air leakage is based on operation between 32 °F (0 °C) and 120 °F (49 °C).

The following sizes of TAMCO Series 9000 dampers with SC or SW Options, and SP – Standard Profile were tested: 12" x 48" (305 mm x 1220 mm), 36" x 36" (915 mm x 915 mm), 48" x 36" (1220 mm x 915 mm), 60" x 36" (1524 mm x 915 mm).

AMCA LEAKAGE CLASS DEFINITIONS

Pressure Class	MAXIMUM ALLOWABLE LEAKAGE CFM/ft ² (l/s/m ²)			
	1 in. w.g. 0.25 kPa	4 in. w.g. 1.0 kPa	6 in. w.g. 1.5 kPa	8 in. w.g. 2.0 kPa
1A	3 (15.2)	n/a	n/a	n/a
1	4 (20.3)	8 (40.6)	9.8 (49.8)	11.3 (57.4)
2	10 (50.8)	20 (102)	24.5 (125)	28.3 (144)
3	40 (203)	80 (406)	98 (498)	113 (574)

NOTE: TAMCO Leakage Class Rating is not provided for dampers measuring more than 48" (1220 mm) wide at 6 in. w.g. (1.5 kPa) and at 8 in. w.g. (2.0 kPa), as the recommended blade length is exceeded at these static pressures. (Refer to the Blade Design Pressure Limitations Chart.)

SP – Standard Profile
With SC Option or SW Option

**EPDM VS. SILICONE UPGRADE OPTION BLADE SEALS
LEAKAGE COMPARISON GRAPH**

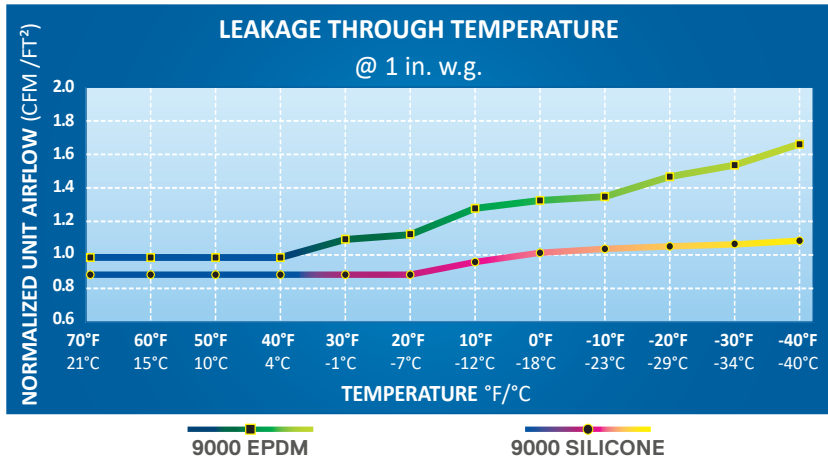

Damper tests were conducted in a laboratory cold room to determine the effects of severe cold temperatures, down to -40 °F (-40 °C) on sealing gaskets and leakage rates.

NOTE: Leakage rates shown in this graph are not licensed to bear the AMCA Seal. There is no AMCA standard dealing with the testing of leakage in temperatures below 32 °F (0 °C).

SEAL PERFORMANCE COMPARISON GRAPH

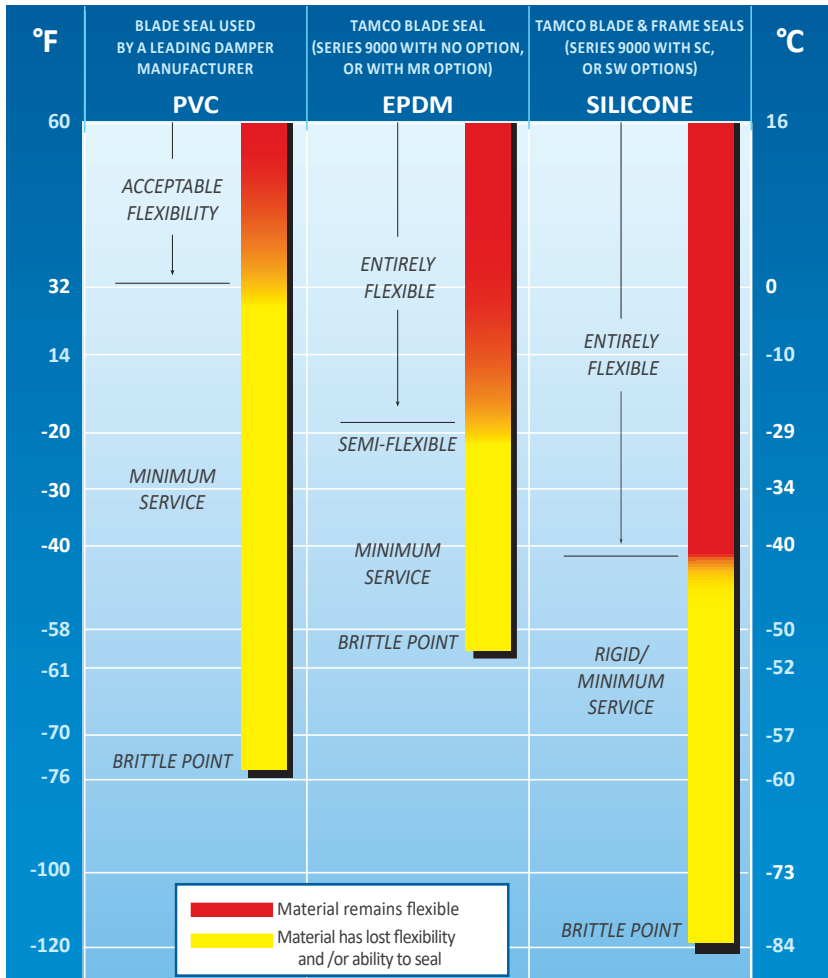

Minimum service temperatures and brittle points are as stated by material manufacturers. Flexibility, rigidity, and suitability status of various materials were determined by observation and operation of dampers in both cold room and cold box environments.

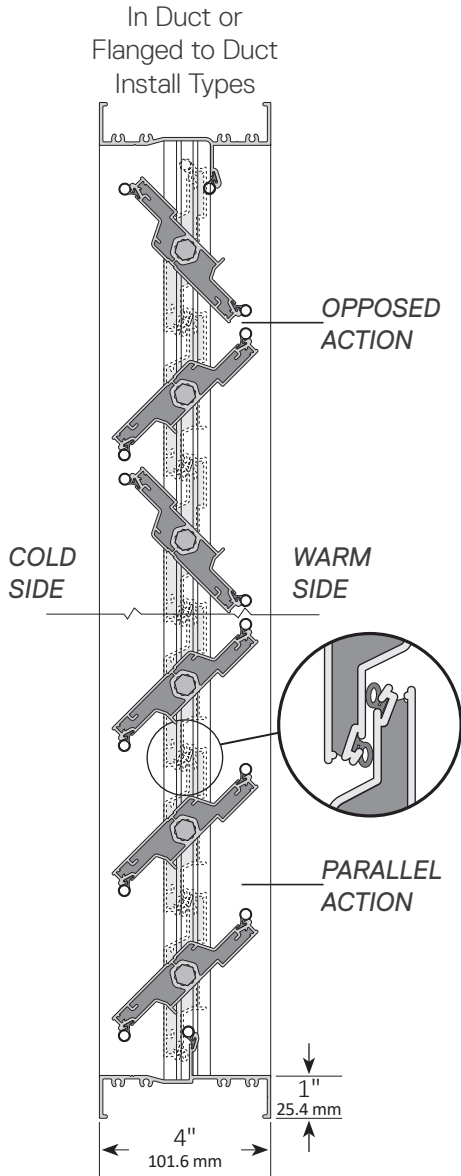

1. Extruded aluminum (6063-T5) damper frame is not less than 0.080" (2.03 mm) in thickness. Damper frame is 4" (101.6 mm) deep x 1" (25.4 mm), with mounting flanges on both sides of frame. Damper frame has a 2" (50.8 mm) mounting flange on the rear of the damper, when ordered as Extended Rear Flange install type.
2. Blades are 4" (101.6 mm) deep extruded aluminum (6063-T5) profiles, internally insulated with expanded polyurethane foam and thermally broken. Complete blade has an insulating factor of R-2.29. Each blade seal extends only 0.2" (5.1 mm) beyond the frame when in the full open position. All blades are symmetrically pivoted.
3. Blade seals are extruded EPDM. Frame seals are extruded silicone. Seals are secured in an integral slot within the aluminum extrusions. Blade and frame seals are mechanically fastened to prevent shrinkage and movement over the life of the damper.
4. Bearings are composed of a Celcon inner bearing - fixed around a 7/16" (11.11 mm) aluminum hexagon blade pivot pin - rotating within a polycarbonate outer bearing inserted in the frame. This eliminates action between metal-to-metal or metal-to-plastic riding surfaces.
5. Adjustable 7/16" (11.11 mm) hexagonal drive rod, U-bolt fastener, and hexagonal retaining nuts are zinc-plated steel. These provide a positive connection to blades and linkage.
6. Aluminum and corrosion-resistant zinc-plated steel linkage hardware is installed in the frame side, complete with cup-point trunnion screws for a slip-proof grip.
7. Dampers are designed for operation in temperatures ranging from -40 °F (-40 °C) to 212 °F (100 °C).
8. Leakage rate through a 36" x 36" (915 mm x 915 mm) does not exceed 1.19 cfm/ft² (6.0 l/s/m²) against 1 in. w.g. (0.25 kPa) differential static pressure. Tested in accordance with ANSI/AMCA Standard 500-D.
9. Dampers are custom made to required size, without blanking off free area. The blade stop is set at a fixed height and is a continuous and integral part of the top and bottom frames.
10. Dampers are available with either opposed blade action or parallel blade action.
11. Dampers are available in four install types: Installed In Duct, Flanged to Duct, Extended Rear Flange, and Square to Round Transition. (See Install Type pages for details.)
12. Installation of dampers must be in accordance with TAMCO's current on-line installation guidelines. (Printed installation guidelines are provided with each damper shipment, however all technical information available on TAMCO's web site at www.tamcodampers.com supersedes information contained within printed versions.)
13. Intermediate structural support is required to resist applied pressure loads for dampers that consist of two or more sections in both height and width. (See TAMCO Aluminum Damper Installation Guidelines.)

OPTIONS FOR NP – NARROW PROFILE:

For each option listed, replace the lines above with their corresponding lines below.

SC - SEVERE COLD TEMPERATURE OPTION:

3. Blade and frame seals are extruded silicone, for reduced air leakage at colder temperatures. Blade and frame seals are secured in an integral slot within the aluminum extrusions and are mechanically fastened to prevent shrinkage and movement over the life of the damper.
8. Leakage rate through a 48" x 36" (1220 mm x 915 mm) does not exceed 1.07 cfm/ft² (5.4 l/s/m²) against 1 in. w.g. (0.25 kPa) differential static pressure. Tested in accordance with ANSI/AMCA Standard 500-D.

MR - MOISTURE RESISTANCE OPTION:

1. Extruded aluminum (6063-T5) damper frame is not less than 0.080" (2.03 mm) in thickness. Damper frame is 4" (101.6 mm) deep x 1" (25.4 mm), with mounting flanges on both sides of frame. Damper frame has a 2" (50.8 mm) mounting flange on the rear of the damper, when ordered as Extended Rear Flange install type. Frame is assembled using stainless steel screws.
5. Adjustable 7/16" (11.11 mm) hexagonal drive rod, U-bolt fastener, and hexagonal retaining nuts are stainless steel. These provide a positive connection to blades and linkage.
6. Aluminum and stainless steel linkage hardware is installed in the frame side, complete with stainless steel cup-point trunnion screws for a slip-proof grip.

SW - SALT WATER RESISTANCE OPTION:

1. Extruded aluminum (6063-T5) damper frame is not less than 0.080" (2.03 mm) in thickness. Damper frame is 4" (101.6 mm) deep x 1" (25.4 mm), with mounting flanges on both sides of frame. Damper frame has a 2" (50.8 mm) mounting flange on the rear of the damper, when ordered as Extended Rear Flange install type. Aluminum frame is clear anodized to a minimum depth of 0.7 mil (18 microns). Frame is assembled using stainless steel screws.
2. Blades are 4" (101.6 mm) deep extruded aluminum (6063-T5) profiles, internally insulated with expanded polyurethane foam and thermally broken. Complete blade has an insulating factor of R-2.29. Each blade seal extends only 0.2" (5.1 mm) beyond the frame when in the full open position. All blades are symmetrically pivoted. Extruded aluminum blades are clear anodized to a minimum depth of 0.7 mil (18 microns).
3. Blade and frame seals are extruded silicone, for reduced air leakage at colder temperatures. Blade and frame seals are secured in an integral slot within the aluminum extrusions and are mechanically fastened to prevent shrinkage and movement over the life of the damper.
5. Adjustable 7/16" (11.11 mm) hexagonal drive rod, U-bolt fastener, and hexagonal retaining nuts are stainless steel. These provide a positive connection to blades and linkage.
6. Clear anodized aluminum and stainless steel linkage hardware is installed in the frame side, complete with stainless steel cup-point trunnion screws for a slip-proof grip.
8. Leakage rate through a 48" x 36" (1220 mm x 915 mm) does not exceed 1.07 cfm/ft² (5.4 l/s/m²) against 1 in. w.g. (0.25 kPa) differential static pressure. Tested in accordance with ANSI/AMCA Standard 500-D.

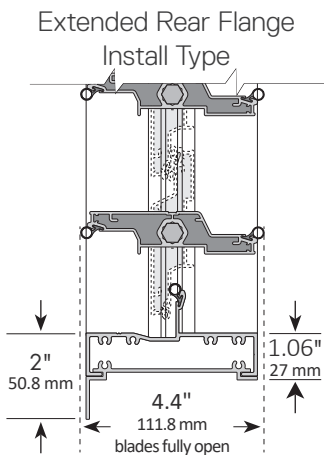

VELOCITY VS. PRESSURE DROP

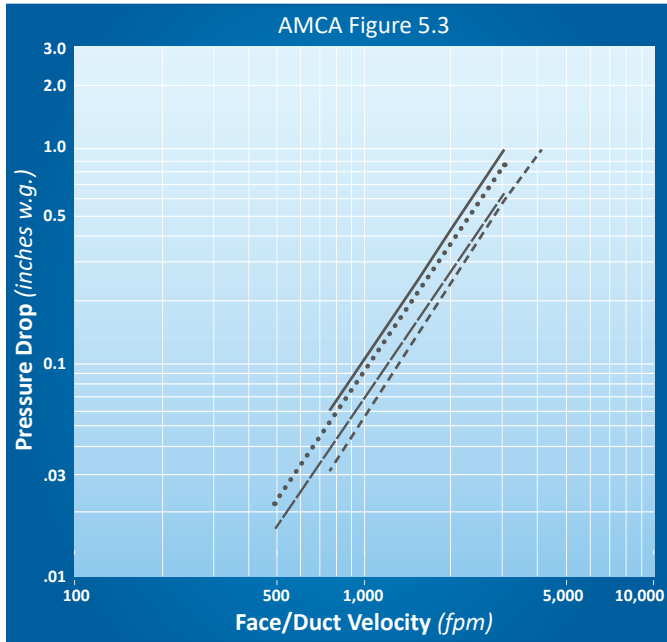

LEGEND:

12" x 12" (305 mm x 305 mm)

12" x 24" (305 mm x 610 mm)

24" x 12" (610 mm x 305 mm)

24" x 24" (610 mm x 610 mm)

FIG. 5.3 Test damper is fully ducted with a 5 diameter duct run upstream, and a 6 diameter duct run downstream. Air Performance testing was conducted in accordance with ANSI/AMCA Standard 500-D.

Pressure drop values are based on Flanged to Duct install type. Pressure drop will be greater for In Duct install type dampers.

BLADE DESIGN PRESSURE LIMITATIONS

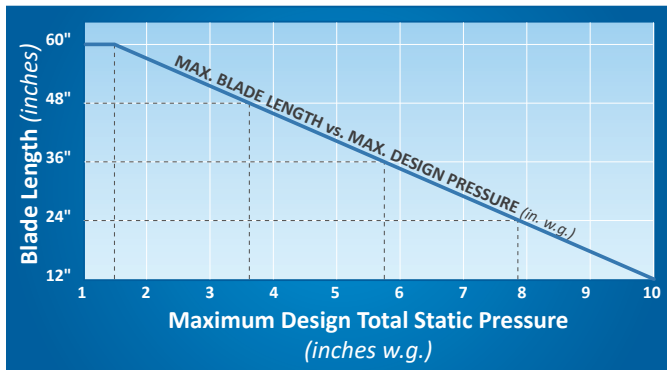

Series 9000 dampers with NP – Narrow Profile, whose blade length exceeds the maximum design pressure, may be reconfigured to maintain a blade length compatible with the required system pressure by increasing the number of sections per damper and thereby reducing each damper section's blade length. Appropriate intermediate structural support will be required for all multiple-section damper assemblies. (Refer to line 13 of the Submittal Data and to TAMCO's Aluminum Damper Installation Guidelines.)

Example:

A single-section damper of 60" w x 36" h (1524 mm x 915 mm) at 5 in. w.g. (1.24 kPa) would need to be built in two sections of 30" w x 36" h (762 mm x 915 mm).

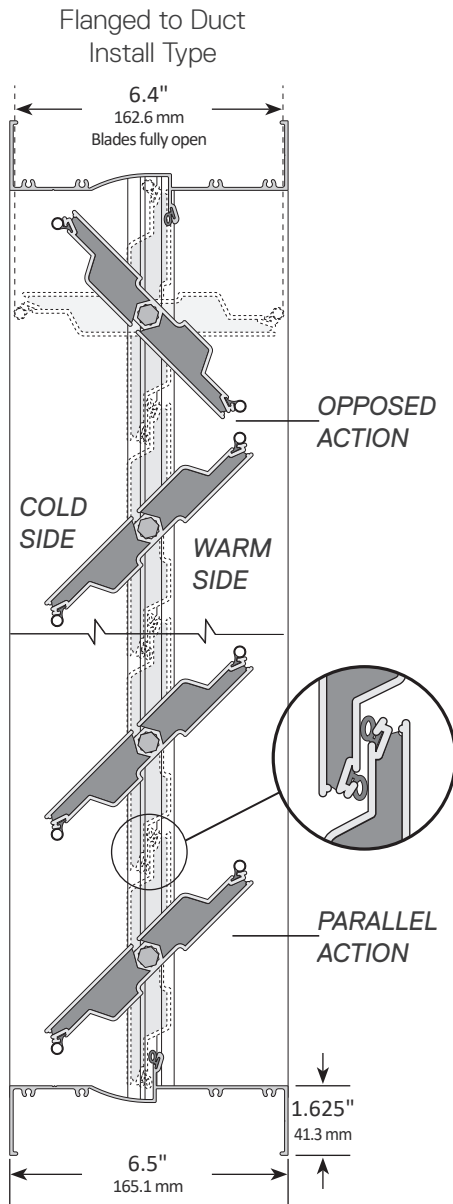

1. Extruded aluminum (6063-T5) damper frame is not less than 0.080" (2.03 mm) in thickness. Damper frame is 6.5" (165.1 mm) deep x 1.625" (41.3 mm), with mounting flanges on both sides of frame.
2. Blades are maximum 6" (152.4 mm) deep extruded aluminum (6063-T5) air-foil profiles, internally insulated with expanded polyurethane foam and thermally broken. Complete blade has an insulating factor of R-2.29. All blades are symmetrically pivoted.
3. Blade seals are extruded EPDM. Frame seals are extruded silicone. Seals are secured in an integral slot within the aluminum extrusions. Blade and frame seals are mechanically fastened to prevent shrinkage and movement over the life of the damper.
4. Bearings are composed of a Celcon inner bearing - fixed around a 7/16" (11.11 mm) aluminum hexagon blade pivot pin - rotating within a polycarbonate outer bearing inserted in the frame. This eliminates action between metal-to-metal or metal-to-plastic riding surfaces.
5. Adjustable 7/16" (11.11 mm) hexagonal drive rod, U-bolt fastener, and hexagonal retaining nuts are zinc-plated steel. These provide a positive connection to blades and linkage.
6. Aluminum and corrosion-resistant zinc-plated steel linkage hardware is installed in the frame side, complete with cup-point trunnion screws for a slip-proof grip.
7. Dampers are designed for operation in temperatures ranging from -40 °F (-40 °C) to 212 °F (100 °C).
8. Leakage rate through a 36" x 36" (915 mm x 915 mm) does not exceed 0.99 cfm/ft² (5.0 l/s/m²) against 1 in. w.g. (0.25 kPa) differential static pressure. Tested in accordance with ANSI/AMCA Standard 500 D.
9. Dampers are custom made to required size, without blanking off free area. The blade stop is set at a fixed height and is a continuous and integral part of the top and bottom frames.
10. Dampers are available with either opposed blade action or parallel blade action.
11. Dampers are available as Flanged to Duct install type only. (See Install Type pages for details.)
12. Installation of dampers must be in accordance with TAMCO's current on-line installation guidelines. (Printed installation guidelines are provided with each damper shipment, however all technical information available on TAMCO's web site at www.tamcodampers.com supersedes information contained within printed versions.)
13. Intermediate structural support is required to resist applied pressure loads for dampers that consist of two or more sections in both height and width. (See TAMCO Aluminum Damper Installation Guidelines.)

OPTIONS FOR WP – WIDE PROFILE:

For each option listed, replace the lines above with their corresponding lines below.

SC - SEVERE COLD TEMPERATURE OPTION:

3. Blade and frame seals are extruded silicone, for reduced air leakage at colder temperatures. Blade and frame seals are secured in an integral slot within the aluminum extrusions and are mechanically fastened to prevent shrinkage and movement over the life of the damper.
8. Leakage rate through a 48" x 36" (1220 mm x 915 mm) does not exceed 0.89 cfm/ft² (4.5 l/s/m²) against 1 in. w.g. (0.25 kPa) differential static pressure. Tested in accordance with ANSI/AMCA Standard 500 D.

MR - MOISTURE RESISTANCE OPTION:

1. Extruded aluminum (6063-T5) damper frame is not less than 0.080" (2.03 mm) in thickness. Damper frame is 6.5" (165.1 mm) deep x 1.625" (41.3 mm), with mounting flanges on both sides of frame. Frame is assembled using stainless steel screws.
5. Adjustable 7/16" (11.11 mm) hexagonal drive rod, U-bolt fastener, and hexagonal retaining nuts are stainless steel. These provide a positive connection to blades and linkage.
6. Aluminum and stainless steel linkage hardware is installed in the frame side, complete with stainless steel cup-point trunnion screws for a slip-proof grip.

SW - SALT WATER RESISTANCE OPTION:

1. Extruded aluminum (6063-T5) damper frame is not less than 0.080" (2.03 mm) in thickness. Damper frame is 6.5" (165.1 mm) deep x 1.625" (41.3 mm), with mounting flanges on both sides of frame. Aluminum frame is clear anodized to a minimum depth of 0.7 mil (18 microns). Frame is assembled using stainless steel screws.
2. Blades are maximum 6" (152.4 mm) deep extruded aluminum (6063-T5) air-foil profiles, internally insulated with expanded polyurethane foam and thermally broken. Complete blade has an insulating factor of R-2.29. All blades are symmetrically pivoted. Extruded aluminum blades are clear anodized to a minimum depth of 0.7 mil (18 microns).
3. Blade and frame seals are extruded silicone, for reduced air leakage at colder temperatures. Blade and frame seals are secured in an integral slot within the aluminum extrusions and are mechanically fastened to prevent shrinkage and movement over the life of the damper.
5. Adjustable 7/16" (11.11 mm) hexagonal drive rod, U-bolt fastener, and hexagonal retaining nuts are stainless steel. These provide a positive connection to blades and linkage.
6. Clear anodized aluminum and stainless steel linkage hardware is installed in the frame side, complete with stainless steel cup-point trunnion screws for a slip-proof grip.
8. Leakage rate through a 48" x 36" (1220 mm x 915 mm) does not exceed 0.89 cfm/ft² (4.5 l/s/m²) against 1 in. w.g. (0.25 kPa) differential static pressure. Tested in accordance with ANSI/AMCA Standard 500 D.

VELOCITY VS. PRESSURE DROP

SIZE <i>inches</i>	VELOCITY <i>fpm</i>	PRESSURE DROP (<i>inches w.g.</i>)					
		AMCA Fig. 5.4 (<i>Intake</i>)			AMCA Fig. 5.5 (<i>Exhaust</i>)		
		DAMPER & SYSTEM	SYSTEM ONLY	DAMPER ONLY	DAMPER & SYSTEM	SYSTEM ONLY	DAMPER ONLY
12 X 48	1000	0.168	0.166	0.002	0.151	0.155	-0.004
	2000	.0649	0.654	-0.005	0.618	0.638	-0.020
	3000	1.483	1.482	0.001	1.389	1.458	-0.069
24 X 24	1000	0.171	0.164	0.007	0.161	0.159	0.002
	2000	0.666	0.658	0.008	0.672	0.653	0.019
	3000	1.514	1.478	0.037	1.523	1.471	0.052
36 X 36	1000	0.180	0.172	0.008	0.166	0.157	0.009
	2000	0.716	0.685	0.031	0.671	0.634	0.037
	3000	1.613	1.547	0.066	1.509	1.427	0.082
48 X 12	1000	0.168	0.166	0.002	0.152	0.155	-0.003
	2000	0.669	0.654	0.015	0.628	0.638	-0.010
	3000	1.497	1.482	0.015	1.423	1.458	-0.035
48 X 48	1000	0.176	0.169	0.007	0.160	0.155	0.005
	2000	0.704	0.673	0.031	0.644	0.613	0.031
	3000	1.571	1.520	0.052	1.428	1.394	0.034

FIG. 5.4 Test damper is located at the entrance of a plenum.

FIG. 5.5 Test damper is located at the exit of a plenum.

Air Performance testing was conducted in accordance with ANSI/AMCA Standard 500-D.

Pressure drop values are based on Flanged to Duct install type. Pressure drop will be greater for In Duct install type dampers.

The table above shows AMCA Figure 5.4 (intake) and Figure 5.5 (exhaust) pressure drop test results for a range of opening sizes. Pressure drop tests were conducted for each of the following:

- System Only. (No damper installed in the opening.)
- Damper & System. (TAMCO damper installed in the opening.)

The third column (Damper Only) under each AMCA Figure shows what effect the TAMCO WP dampers have on the airflow through each opening size. This is calculated by subtracting the Damper and System results from the System Only results.

BLADE DESIGN PRESSURE LIMITATIONS

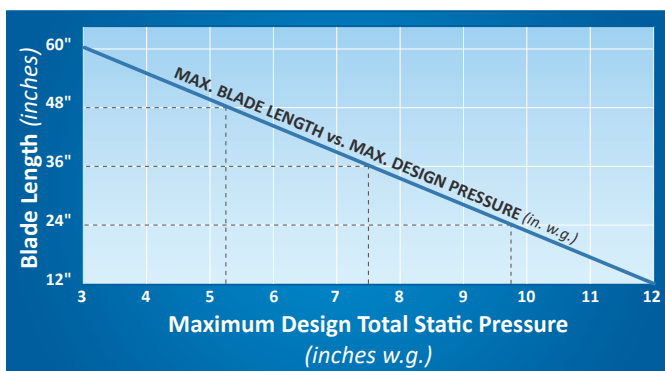

Series 9000 dampers with WP – Wide Profile, whose blade length exceeds the maximum design pressure, may be reconfigured to maintain a blade length compatible with the required system pressure by increasing the number of sections per damper and thereby reducing each damper section's blade length. Appropriate intermediate structural support will be required for all multiple-section damper assemblies. (Refer to line 13 of the Submittal Data and to TAMCO's Aluminum Damper Installation Guidelines.)

Example:

A single-section damper of 60”w x 36”h (1524 mm x 915 mm) at 5 in. w.g. (1.24 kPa) would need to be built in two sections of 30”w x 36”h (762 mm x 915 mm).

INSTALL TYPES | Series 9000

Thermally Insulated Damper with Thermally Broken Blades

- Always provide opening width and height dimensions, when ordering.
- Width dimension is always parallel to blades.
- Height dimension is always perpendicular to blades.

INSTALLED IN DUCT TYPE

- Applies to SP and NP Profiles only. Not available for WP Profile.
- Finished damper O.D. is $\frac{1}{2}$ " (12.7 mm) less than opening width and height dimensions.

MINIMUM SECTION SIZE:

SP $6\frac{1}{2}$ "w x $6\frac{3}{4}$ "h (166 mm x 172 mm)

NP $6\frac{1}{2}$ "w x $12\frac{5}{8}$ "h (166 mm x 320 mm)

MAXIMUM SECTION SIZE:

25 ft² (2.3 m²)

60"w x 60"h or (1524 mm x 1524 mm) or

48"w x 75"h (1220 mm x 1905 mm)

- Minimum section width is 8" (203 mm) for dampers ordered with vertical jackshafts.



FLANGED TO DUCT TYPE

- For SP and NP Profiles, finished damper O.D. is 2" (50.8 mm) greater than opening width and height dimensions.
- For WP Profile, finished damper O.D. is 3.25" (82.6 mm) greater than opening width and height dimensions.

MINIMUM SECTION SIZE:

SP/WP $4\frac{1}{2}$ "w x $4\frac{1}{4}$ "h (115 mm x 108 mm)

NP $4\frac{1}{2}$ "w x $10\frac{1}{8}$ "h (115 mm x 257 mm)

MAXIMUM SECTION SIZE:

25 ft² (2.3 m²)

60"w x 60"h or (1524 mm x 1524 mm) or

48"w x 75"h (1220 mm x 1905 mm)



EXTENDED REAR FLANGE TYPE

- Applies to SP and NP Profiles only. Not available for WP Profile.
- Finished damper O.D. is 4" (101.6 mm) greater than opening width and height dimensions.

MINIMUM SECTION SIZE:

SP $4\frac{1}{2}$ "w x $4\frac{1}{4}$ "h (115 mm x 108 mm)

NP $4\frac{1}{2}$ "w x $10\frac{1}{8}$ "h (115 mm x 257 mm)

MAXIMUM SECTION SIZE:

25 ft² (2.3 m²)

60"w x 60"h or (1524 mm x 1524 mm) or

48"w x 75"h (1220 mm x 1905 mm)

- Extended Rear Flange install type dampers are not designed so that the front of the damper may be inserted into an opening, as the side frame members extend to the full height of the rear flange.



SQUARE TO ROUND TRANSITION

- Applies to SP and NP Profiles only. Not available for WP Profile.
- Always provide duct diameter dimension when ordering.
- If using TAMCO Connect software to submit orders, enter duct diameter dimension in both the width and height fields.
- Transition pieces are a minimum of 18 ga. galvanized steel for Series 9000 dampers, when ordered no option or with the SC Option.
- Transition pieces are 304 stainless steel, when Series 9000 dampers are ordered with MR or SW Options.
- Transition pieces and damper are sealed together.
- Dampers are built 4" (102 mm) larger than specified duct diameter. *(Dampers are fabricated square.)*
- Finished transition diameter is ¼" (6.35 mm) less than specified duct diameter, providing clearance for mating duct which slides over round transition. This ensures free movement of damper blades.

MINIMUM DUCT DIAMETER:		
SP	4"	(102 mm)
NP	8 ½"	(206 mm)
MAXIMUM DUCT DIAMETER:		
	58"	(1474 mm)
MAXIMUM SECTION SIZE:		
	25 ft ²	(2.3 m ²)
MAXIMUM FINISHED OD:		
	62" w x 62" h	(1575 mm x 1575 mm)

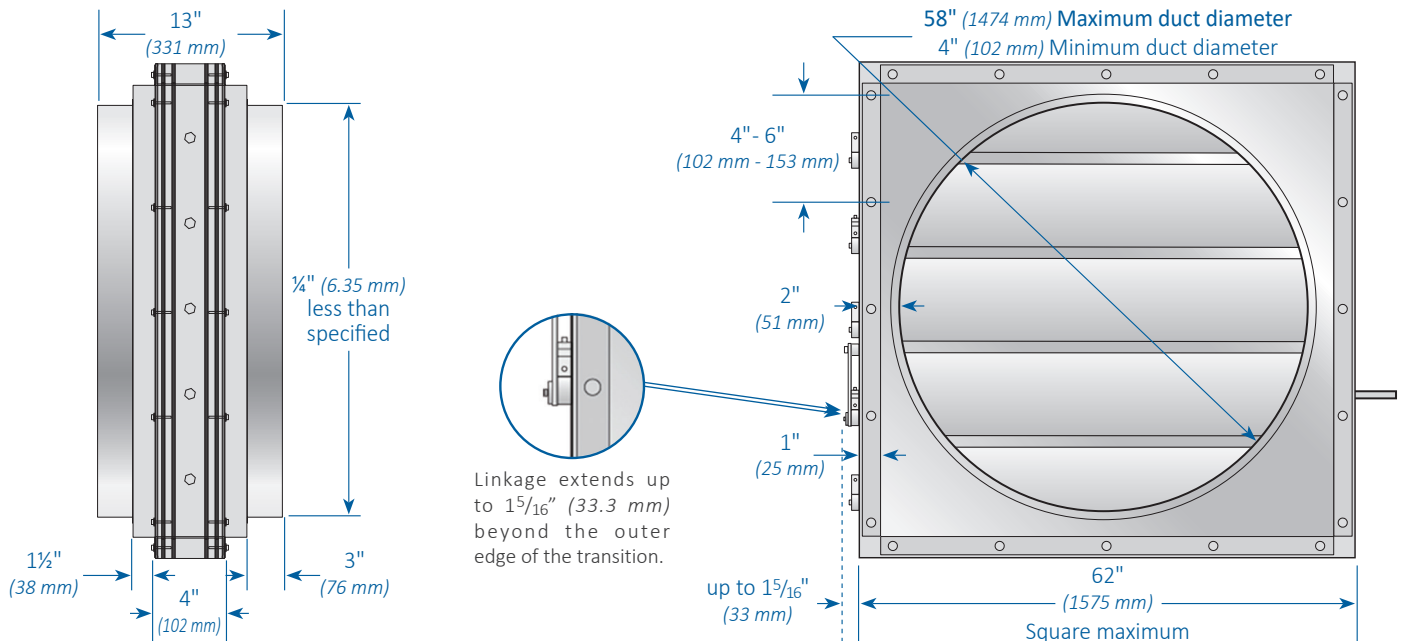

NOTE:

- To reduce pressure drop, use Flanged to Duct or Extended Rear Flange install types for sizes under 9 ft² (.83 m²).
- Suitable for operation in breathable air environments within stated temperature range.
- SP and WP dampers sized for duct openings exceeding 37 ¼" (959 mm) in height and NP dampers sized for duct openings exceeding 35 ¾" (908 mm) are equipped with a brace at mid-height to strengthen and maintain air leakage tolerances.
- Thermally insulated dampers should not be installed or stored in locations where insulation is in direct line of sight of sunlight or UV light.

FOR ADDITIONAL INFORMATION REFER TO:



INSTALLATION GUIDELINES UNDER THE DOCUMENTS TAB:

- TAMCO Aluminum Control Damper Installation Guidelines.
- Installing Vertical Blade Damper
- Damper Jumper Installation Guidelines
- Horizontal Jackshaft Installation Guidelines
- Vertical Jackshaft Installation Guidelines.



INSTALLATION GUIDELINE VIDEOS

SPX ENGINEERED AIR MOVEMENT

80 Lorne Street
Smiths Falls, ON K7A 5J7, Canada
800 561 3449
tamcodampers.com

TA-9000-TECH-24 | ISSUED 01/2024
© 2024 SPX Engineered Air Movement | All rights reserved
In the interest of technological progress, all products are
subject to design and/or material change without notice.