

**TAMCO** 

**ALUMINUM CONTROL DAMPER**  
INSTALLATION GUIDELINES - OPERATION - MAINTENANCE



**READ ENTIRE INSTALLATION GUIDELINE MANUAL BEFORE INSTALLING DAMPERS.**



TAMCO'S ALL-ALUMINUM CONTROL DAMPERS ARE CONSTRUCTED WITH MAINTENANCE-FREE BEARING AND LINKAGE COMPONENTS.

**CAUTION:**

- Never use any lubricants, such as grease or silicone, on any damper parts, including linkage, bearings or hardware. Lubricants attract dust. Accumulated dust particles can abrade and cause damage to damper bearings.
- However, if a damper includes a jackshaft with a grease fitting, the jackshaft bearings might need to be lightly lubricated once every twelve months, depending on the level of use. Suitable lubricants include high-temperature lithium or silicone grease. Jackshaft bearings without a grease fitting do not require lubricant.
- In applications where the humidity level is unusually elevated, or where there are extremely high levels of dust and dirt particles, TAMCO recommends that the damper linkage and bearing system should be cleaned once a year. This can be done by blowing away dust using compressed air. If needed, a domestic-strength steam cleaner can be used to loosen dirt, which can then be blown out with compressed air, along with any remaining water droplets.
- **DO NOT ADJUST LINKAGE MECHANISM! IF PROBLEM STILL EXISTS AFTER VERIFICATION AND CORRECT ACTION, CALL TAMCO CUSTOMER SERVICE.**

**STORAGE RECOMMENDATIONS:**

- Store control dampers indoors to protect from dirt, dust, and weather. The storage space must be clean, dry, and free of elevated humidity or possible condensation. Do not store at temperatures in excess of 100 °F (38 °C).
- The air must be breathable and contaminant-free.
- The dampers must be stored upright. They must not be stacked on top of, or leaning against each other.
- Thermally insulated dampers should not be installed or stored in locations where the insulation is in direct line of sight of sunlight or UV light.

**Note that all technical information available on TAMCO's website at [www.tamcodampers.com](http://www.tamcodampers.com) supersedes and takes precedence over all information contained within the printed catalog.**

CALL TAMCO CUSTOMER SERVICE WITH ANY QUESTIONS CONCERNING TAMCO DAMPERS

**1-800-561-3449**

## VERIFY DAMPER OPERATION BEFORE INSTALLATION!

- ✓ Before installing, inspect damper for possible damage caused in shipping, and that it has not been racked or twisted. Measure the damper from corner to corner to verify that it is square.
- ✓ If minor damage has occurred to frame corners or flanges, correct by bending or hammering back into position. Ensure correct realignment of repair, as bent or twisted frames might not mate properly with mounting angles, or additional damper sections.
- ✓ Do not install damper if damage is more than superficial. If uncertain as to extent of damage, or if damper does not seal correctly, **call TAMCO Customer Service at 1-800-561-3449.**
- ✓ Operate damper section manually (*on a flat section of floor*) to verify correct blade action and sealing.

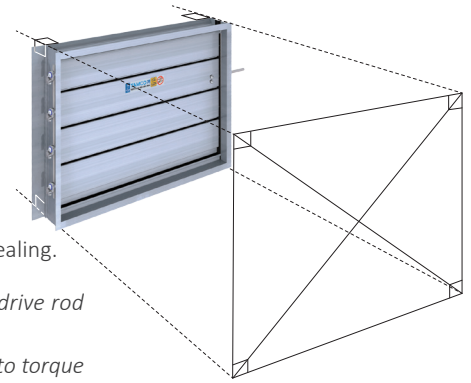

- (A) To correctly verify sealing action, loosen hex nuts of U-bolt located on drive blade. Extend steel drive rod to maximum of 8" beyond the outside edge of the frame. Re-tighten hex nuts on U-bolt.
- (B) Using drive rod, slowly apply closing torque, while ensuring that damper frame does not twist due to torque being applied. Larger dampers may require additional person to hold damper frame square and true.
- (C) If possible, use daylight or inside light source as a backdrop while verifying blade operation. No light should be visible through damper.

**EXERCISE CAUTION TO ENSURE FINGERS  
ARE NOT IN WAY OF MOVING LINKAGE PARTS OR BLADES.**

## INSTALLATION GUIDELINES | for TAMCO Aluminum Control Dampers

### General Installation Notes



VISIT OUR WEB PAGE AT

[www.tamcodampers.com/inGde\\_videos.php](http://www.tamcodampers.com/inGde_videos.php)

FOR VIDEO INSTALLATION GUIDELINES



**FRONT / TOP END UP / RIGHT HAND**

- TAMCO label is always adhered to the damper's drive blade, on the front (face) side of the damper.
- When labels on blades are viewed right side up, the damper orientation is Front/Top end up.
- When viewed as Front/Top end up, a right-hand (RH) damper has the drive rod as shown. Left-hand (LH) dampers have a drive rod on the left.
- The damper, as a complete unit, can be installed right side up, upside down, standing up, or lying flat.
- There is no specified air entry or air exhaust side for Series 1000, 1500, 9000, and 9000 BF dampers. This includes all applicable Options.
- Series 9000 and 9000 BF dampers must be installed so that the blade side with the thermal break along the center of the face of the blade is on the cold side.
- The system must support the damper. The damper cannot support the system.
- Duct work construction and bracing must be sufficient to support the damper. Do not use the damper to square up duct work.
- Joiners and fasteners, provided by TAMCO to interconnect damper sections, are for alignment purposes only and may not be considered as structural supports.
- Ensure that the damper is installed to permit future access to the side linkage, as well as any damper jumper brackets, or jackshafts, if so supplied.

FOR TAMCO JACKSHAFTS REFER TO INSTRUCTIONS PROVIDED IN PARTS BOX.  
FOR TAMCO JUMPERS REFER TO INSTRUCTIONS PRINTED ON PARTS BOX.

**EXTENDABLE DRIVE ROD**

- A 12" (305 mm) long, hexagonal steel drive rod is provided as standard.
- Dampers are shipped with their drive rod inserted in the drive blade.
- Drive rods may be extended up to a maximum of 8" (203 mm) beyond the outside edge of the frame by loosening the U-bolt, drawing out the rod to the desired length and then retightening the U-bolt.
- If required, 24" (610 mm) and 36" (915 mm) long drive rods can be ordered.
- Drive blades in images are semi-transparent in order to demonstrate placement of obscured portions of drive rods.

RETRACTED FOR SHIPPING



EXTENDED

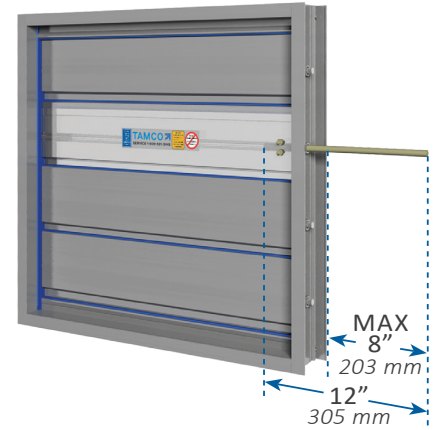

**SECTION DRIVE SIDE**

- Drive side will affect the direction the blades rotate to open and thereby affect the angle of airflow when parallel blades are not in the fully open position.
- Drive side will not affect the angle of airflow for opposed blade dampers.
- Multiple-section wide dampers are always manufactured so that the left most section is left hand drive and the remaining sections are right hand drive.
- It is important to consider drive side when ordering single-section dampers, particularly when parallel blades are required.
- Single-section wide dampers can be ordered with drive rods on both sides.
- If a damper requires a jackshaft that must extend beyond both sides of the damper section or assembly, this must be specified at the time of order.

RIGHT HAND DRIVE



LABEL/  
FRONT  
SIDE



CCW ROTATION  
TO OPEN

LEFT HAND DRIVE



LABEL/  
FRONT  
SIDE



CW ROTATION  
TO OPEN

### INSTALLED IN DUCT TYPE

- Damper must be installed square.
- Damper is manufactured so that finished O.D. is  $\frac{1}{2}$ " (12.7 mm) smaller than opening width and height dimensions.
- Ensure that duct is square and/or large enough to allow damper to be installed square.
- Make hole in duct work, if required, to allow extension of drive rod.
- Bottom of frame must sit flat on floor of duct to prevent twisting, sagging, or bowing, as this could cause leakage between bottom frame and bottom blade.
- Verify that damper is square, plumb, and level. Then secure bottom frame to floor of duct using a 90° mounting angle. Operate damper manually to confirm proper blade sealing.
- As each mounting angle is installed, verify operation to ensure damper blades are sealing correctly.
- 90° mounting angles are field-supplied.
- Caulk all connections/joints between damper frame and duct to minimize installation leakage.

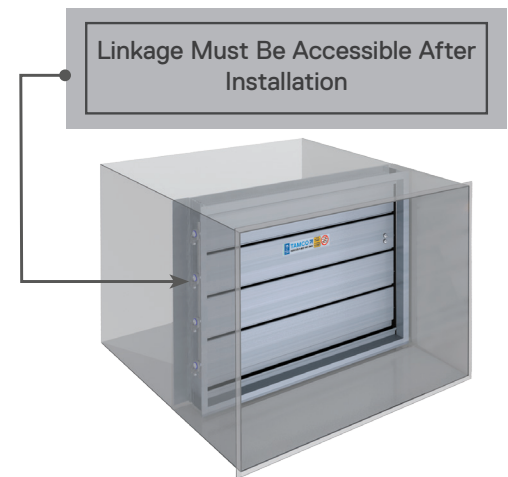

### FLANGED TO DUCT TYPE

- Damper must be installed square.
- Front and rear damper flanges are 1" (25.4 mm) larger than duct or opening, around entire perimeter.
- Damper is manufactured so that finished O.D. is 2" (50.8 mm) greater than opening width and height dimensions.
- Do not assume that duct is square. Verify that duct flange is square, flat and even.
- Verify that damper is square, plumb, and level. Operate damper manually to verify free movement of blades and correct sealing.
- Fasten damper to duct. Re-verify that damper is square.
- Repeat procedure for other flange, if ducted on both sides.
- Caulk all connections/joints between damper frame and duct to minimize installation leakage.



### EXTENDED REAR FLANGE TYPE

- Damper must be installed square.
- Rear damper flange is 2" (50.8 mm) larger than duct or opening, around entire perimeter, providing a larger fastening surface.
- Front damper flange is 1" (25.4 mm) larger than duct or opening, around entire perimeter. *(Note that Extended Rear Flange Install Type dampers are not designed so that the front of the damper may be inserted into an opening, as the side frame members extend to the full height of the rear flange.)*
- Damper is manufactured so that finished O.D. is 4" (101.6 mm) greater than opening width and height dimensions.
- Do not assume that opening is square. Verify that opening or duct flange is square, flat and even.
- Verify that damper is square, plumb, and level. Operate damper manually to verify free movement of blades and correct sealing.
- Fasten damper to opening surface or duct. Re-verify that damper is square.
- Repeat procedure for other flange, if ducted on both sides.
- Caulk all connections/joints between damper frame and opening or duct to minimize installation leakage.



## INSTALLING MULTIPLE-SECTION DAMPERS

IF JACKSHAFTS ARE TO BE FITTED, SEE JACKSHAFT INSTRUCTIONS PRIOR TO INSTALLING DAMPERS

### TWO SECTIONS WIDE

- Frame members are designed to overlap and are manufactured with two aligned positioning holes. When dampers are correctly positioned, holes will be aligned.
- Bolt alignment fasteners are shipped attached to the offset overlapping frame. (*Alignment holes are not meant to be structural. Bracing may be deemed necessary by installer.*)
- Ensure that both sections are straight, even, and aligned with each other.

**ALL ILLUSTRATIONS SHOWN ARE FRONT/TOP END UP DAMPERS**

**RH = RIGHT-HAND DAMPER**  
**LH = LEFT-HAND DAMPER**

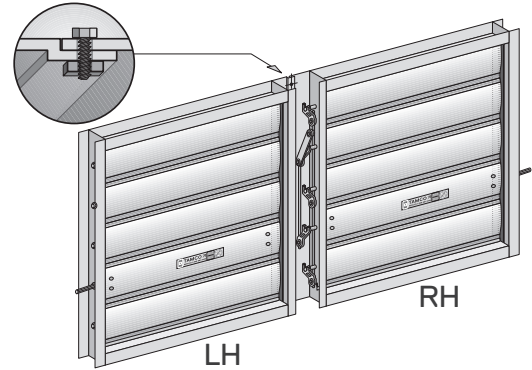

### THREE SECTIONS WIDE

- Frame members are designed to overlap and are manufactured with two aligned positioning holes. When dampers are correctly positioned, holes will be aligned.
- Bolt alignment fasteners are shipped attached to the offset overlapping frame. (*Alignment holes are not meant to be structural. Bracing may be deemed necessary by installer.*)
- Ensure that all three sections are straight, even, and aligned with each other.

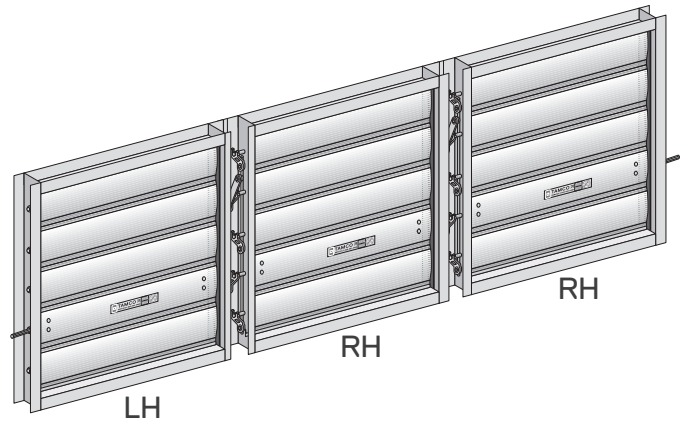

### MULTIPLE SECTIONS WIDE BY MULTIPLE SECTIONS HIGH

- Install bottom tier damper section(s) first.
- Place second level of damper section(s) on top of bottom section(s), being careful that all sections are properly aligned.
- Install top damper section(s).
- Slide joiner(s) over frame member(s), where top and bottom section(s) meet(s).
- Using self-drilling screws, fasten joiner to damper frame member(s) through pre-punched holes in joiner. **Caution: Joiner is not designed to be structural. Additional bracing may be required if deemed necessary by installer.**
- Repeat procedure for all additional section tiers.
- Ensure all sections are straight, even, and aligned with each other.

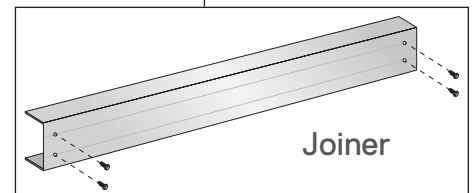
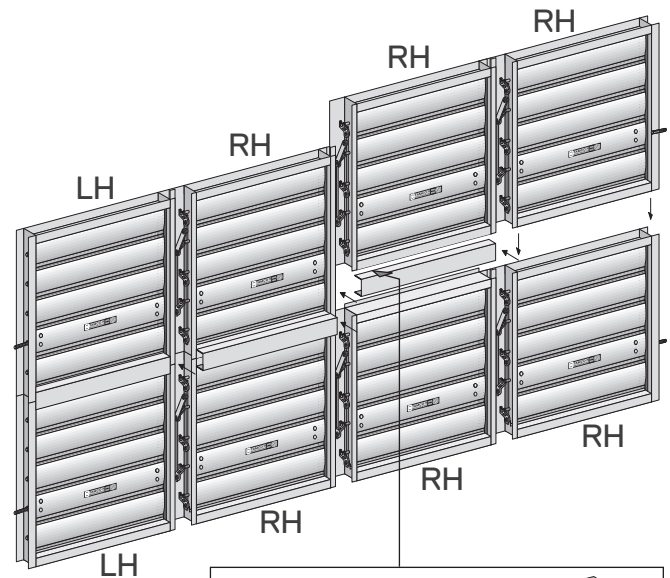

## INSTALLING MULTIPLE-SECTION DAMPERS

### OPTIONAL MULLION END CAPS FOR FLANGED TO DUCT TYPE, MULTIPLE-SECTION DAMPER INSTALLATIONS

- Mullion end caps are provided with all multi-section dampers that are to be installed as Flanged to Duct install type.
- These are required to prevent air flow from passing through open channels. *(Mullion end caps are not intended for use as structural support.)*
- Caulk surfaces between mullion end caps and damper frame for an airtight seal.
- Mullion end caps are not required for Installed in Duct type nor for Extended Rear Flange install type dampers. As such they are not provided as standard, but may be ordered as separate parts.

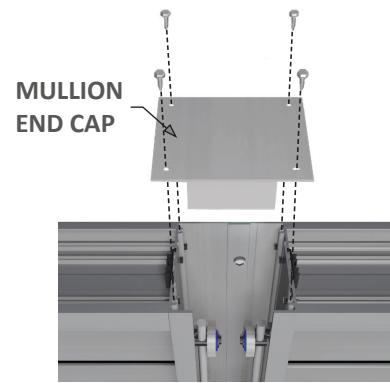

### INTERNAL JUMPER

Connection procedure for two-section wide dampers, supplied with an internal jumper.

1. Set up both damper sections beside each other so that they are arranged in the order indicated in the diagram found on the drive blade sticker.
2. Remove the  $\frac{1}{4}$ -20x $\frac{3}{4}$ " nuts and bolts from the aligned positioning holes at the top and bottom of the damper side frame. *(Normally, the nuts and bolts will be factory-installed on the left damper section, for shipping.)*
3. Rotate the blades of each section to the fully open position. Move the damper sections together, ensuring that the hexagonal drive blade pivot pin on one section is aligned with the adjoining section's internal jumper. *(Normally, the internal jumper will be factory-installed on the left damper section.)*
4. Slide the hexagonal drive blade pivot pin into the internal jumper. Make sure that the positioning holes of both sections are aligned at the top and bottom of the side frames.
5. Insert the bolt through the aligned positioning holes at the top of the joined damper sections and secure by tightening the nut. Repeat this for the bottom of the side frames.
6. Using a  $\frac{5}{32}$ " Allen wrench, tighten the set screws on the internal jumper to secure the connection between the two damper sections. *(If the set screws are difficult to reach, you may rotate the blades until the set screws are more easily accessible.)*
7. Operate damper manually to verify free movement of blades and correct sealing.

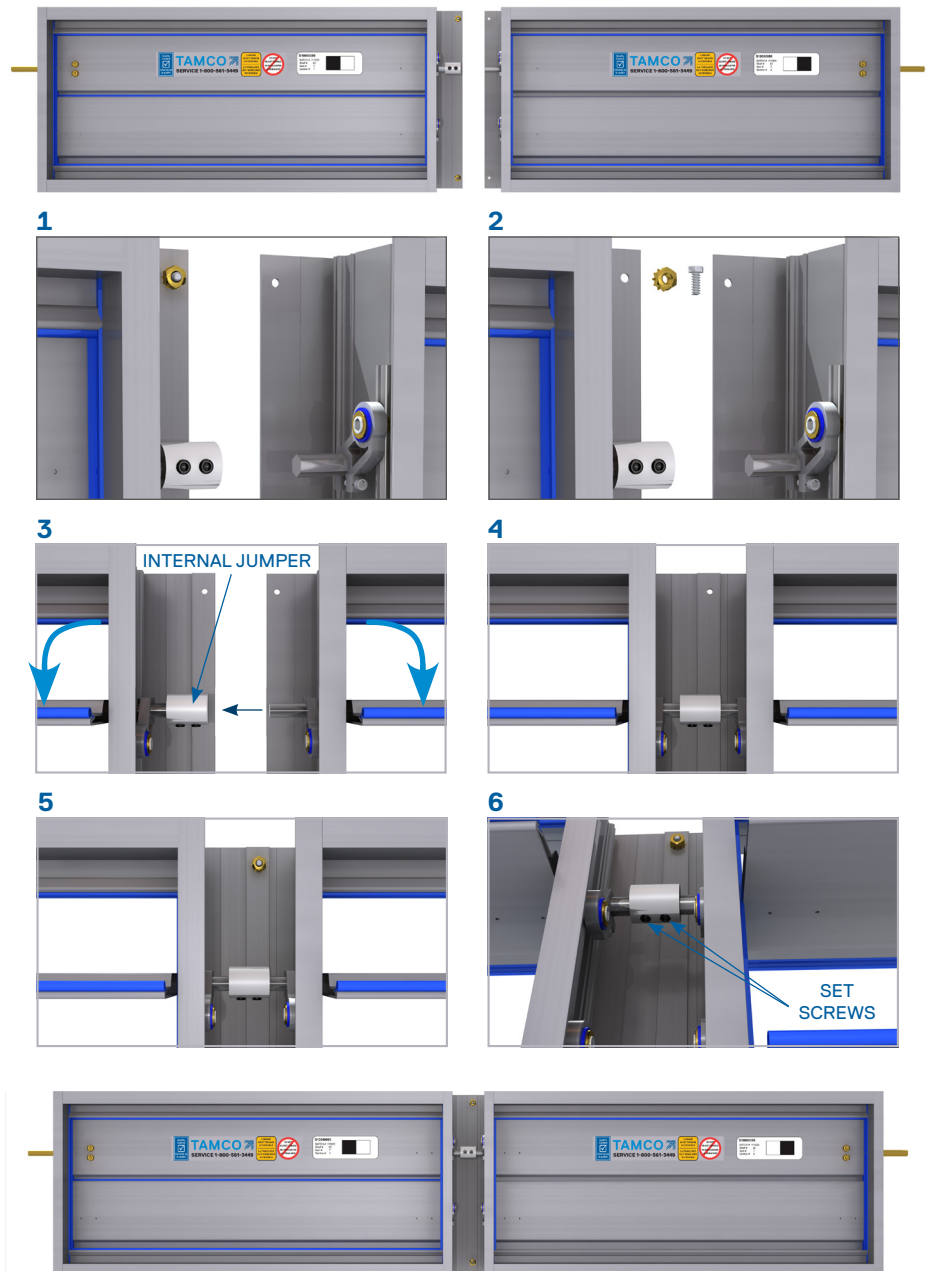

# STRUCTURAL DESIGN REQUIREMENTS

## For Multiple-Section Dampers

### REQUIREMENTS:

- Intermediate structural support is required to resist applied velocity and pressure loads for dampers that consist of two or more sections in both height and width. (See illustration to right.)
- Field-supplied tubular structural steel support may be required for large multi-sectioned dampers.
- A non-insulated TAMCO damper weighs approximately 5 lbs/ft<sup>2</sup> (24.41 kg/m<sup>2</sup>). An insulated TAMCO dampers weighs approximately 6 lbs/ft<sup>2</sup> (29.29 kg/m<sup>2</sup>).

### MAXIMUM DEFLECTION:

- The structure providing intermediate support must be designed to resist the highest pressure load, with deflection of less than L/230. This applies whether the pressure load is created by the mechanical system, by wind load, or if the damper is mounted on the exterior of the building.

**INTERMEDIATE, FIELD-SUPPLIED, STRUCTURAL SUPPORT IS REQUIRED WHEN INSTALLING IN BOTH THE VERTICAL AND HORIZONTAL PLANES.**

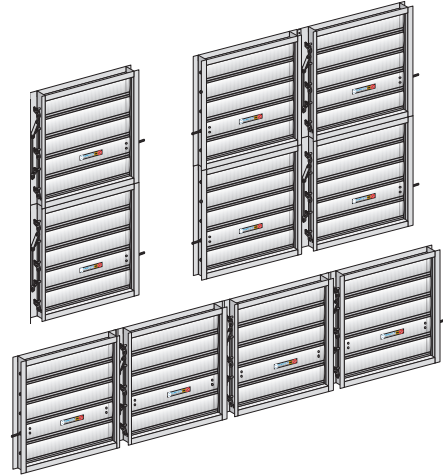

## STRUCTURAL SUPPORT DESIGN FOR TAMCO DAMPERS

### Example:

Design the structural support required to carry TAMCO dampers at the 17<sup>th</sup> story of a building in Ottawa, Ontario, Canada. (Assuming that the maximum internal pressure, as a result of the mechanical systems, is 2 inches of water, 10.4 psf or 500 Pa.)

### Analysis:

Net wind pressure on damper = Exterior pressure or suction + Interior pressure in the mechanical plenum (as specified by the mechanical engineer)

$$p = qC_eC_gC_p \text{ external} + 10.4 \text{ psf} \quad \text{1997 OCB 4.1.8}$$

Where:  $p$  = the specific external pressure acting statically and in a direction normal to the surface, either as a pressure directed towards the surface or as a suction directed away from the surface.

$q$  = the reference velocity pressure based on a 1 in 30 probability of being exceeded in any one year for design of structural members for strength.

$$q_{1/30} = 7.72 \text{ psf} \quad (0.37 \text{ kPa in Ottawa, Ontario}).$$

$C_e$  = exposure factor based on the height of the building (1.4 for a 170 ft. high building).

$C_g$  = gust factor (2.5 for cladding elements and small structural components).

$C_p$  = external pressure coefficient (1.0 for high local suction).

$$p = qC_eC_gC_p \text{ external} + 10.4 \text{ psf}$$

$$p = 7.72 \text{ psf} (1.4) (2.5) (1.0) + 10.4 \text{ psf}$$

$$p = 37.4 \text{ psf}$$

Total net factored pressure:

$$p_f = 1.5 \text{ (live wind load)}$$

$$p_f = 1.5 \cdot (37.4)$$

$$p_f = 56.1 \text{ psf} \quad (2.7 \text{ kPa})$$

Factored distributed load over vertical support framing member:

$$w_f = 56.1 \text{ psf} (5')$$

$$w_f = 281 \text{ lb./ft.}$$

Factored maximum moment:

$$M_f = w_f l^2/8$$

$$M_f = 281 \cdot (10)^2/8$$

$$M_f = 3513 \text{ lb./ft.} \quad (4.8 \text{ kN}\cdot\text{m})$$

### Assumptions:

The subject building is 17 floors high and has plan dimension of 120' by 120' (36.6 m by 36.6 m). The dampers will be mounted on vertical framing members spanning from the 17th floor to the roof slab level.

### Resisting moment:

$M_r$  has to be equal to or greater than  $M_f$  for an unsupported length of 10' (3.05 m)

Acceptable vertical support member:

C4 x 6.25 - 4" structural steel channel  
(metric designation C100 x 9)

$M_r = 3980 \text{ lb.ft.}$  for an unsupported length (Lu) = 13'

( $M_r = 5.4 \text{ kNm}$  at Lu = 4m)

### Check deflection criteria:

Maximum allowable deflection is  $L/230 = 10'/230 = 0.52" (13.2 \text{ mm})$

Maximum deflection at mid-height of the channel:

$$\Delta = \frac{5 w l^4}{384 E I}$$

For deflection, the reference velocity pressure,  $q$ , is based on a 1 in 10 probability of being exceeded in any one year.  $q_{1/10} = 6.27 \text{ psf} (0.30 \text{ kPa in Ottawa, Ontario}).$

$$p = qC_eC_gC_p \text{ external} + 10.4 \text{ psf}$$

$$p = 6.27 \text{ psf} (1.4) (2.5) (1.0) + 10.4 \text{ psf}$$

$$p = 32.3 \text{ psf}$$

$$w = 32.3 \text{ psf} (5')$$

$$w = 162 \text{ lb./ft.}$$

$$\Delta = \frac{5 (162 \text{ lb./ft.}) (10')^4}{384 (29,000 \text{ ksi}) (4.25 \text{ in}^4)}$$

$$\Delta = \frac{5 (13.5 \text{ lb./ft.}) (120'')^4}{384 (29 \cdot 10^6 \text{ psi}) (4.25 \text{ in}^4)} = 0.30 (7.6 \text{ mm})$$

Therefore, an acceptable vertical support member for this example is a C4 x 6.25 (metric designation C100 x 9).



# MOTOR MOUNTING METHODS

## Electric & Pneumatic Actuators

FOR RETROFIT APPLICATIONS, ACTUATORS MUST BE RELOCATED TO MATCH DAMPER DRIVE BLADE POSITION. VISIT OUR WEB PAGE AT [www.tamcodampers.com/inGde\\_videos.php](http://www.tamcodampers.com/inGde_videos.php) FOR VIDEO INSTALLATION GUIDELINES.

### ELECTRIC ACTUATORS



#### DIRECT-COUPLED MOUNTING (EXTERNAL)

- If damper is In Duct Install Type, the motor is attached to the duct using the anti-rotation bracket supplied with the actuator. If the damper is Flanged to Duct Install Type the actuator is mounted to the damper's 4" frame using a TAMCO Motor Mounting Bracket (Part # AL-0001).



#### JACKSHAFT MOUNTING (EXTERNAL)

- Motor is mounted on a mounting bracket.
- Jackshaft measures 1" (25.4 mm) in diameter.



#### FACE MOUNTING (INTERNAL)

- Motor is mounted in the airstream. Damper must be ordered with a TAMCO Face Blade Bracket. Required accessories: Belimo ZG-100 Universal Mounting Bracket (Part # BE-8104), appropriate Belimo Crank Arm Adaptor Kit and Belimo Push Rod (dependent on actuator selected).

### PNEUMATIC ACTUATORS

- Pneumatic motors must be installed and aligned so as to ensure proper rotation of clamp or crank arm. This requires the actuator to be installed at an angle to match blade rotation. Damper drive rod must not be subjected to pressure that may bow or bend rod out of line.
- Each pneumatic actuator requires accessories which are specific to its type, model, or brand. The accessories are necessary to mount the pneumatic actuator to the TAMCO damper hexagonal drive rod,

or to the TAMCO 1" (25.4 mm) diameter jackshaft. Verify with the actuator manufacturer for a list of appropriate accessories.

- TAMCO supplies three sizes of Siemens pneumatic actuators (No. 3, No. 4, and No. 6). Models can be purchased with or without positioners. Required accessories are indicated beneath each pneumatic actuator mounting type image. (Refer to Pneumatic Actuator Mounting Accessories page for more details.)



#### DIRECT-COUPLED MOUNTING (EXTERNAL)

- Required accessories: Pneumatic Actuator Jackshaft Mounting Clevis Crank Arm (Part # PN-0006) and Adaptor-Hex Rod to 1" Diameter (Part # HA-1100).



#### JACKSHAFT MOUNTING (EXTERNAL)

- Required accessory: Pneumatic Actuator Jackshaft Mounting Clevis Crank Arm (Part # PN-0006) and Modified Mounting Plate (Part # PN-0038).

## INSTALLING VERTICAL BLADE DAMPERS

Contact TAMCO CUSTOMER SERVICE for possible configurations not shown.

### SINGLE-SECTION VERTICAL BLADE DAMPER

- TAMCO recommends that single-section vertical blade dampers be installed so that linkage is located at the top.
- The actuator should be mounted on the drive rod which extends beyond the bottom of the damper.
- The lower frame of the damper must be properly braced and supported.



### TWO-SECTION VERTICAL BLADE DAMPER

- Actuators must be mounted on the drive rods.
- Damper sections may be connected with a jumper.
- If sections are connected, the damper must be actuated from only one motor location, either the top or the bottom drive rod.
- The lower frame of the damper must be properly braced and supported.

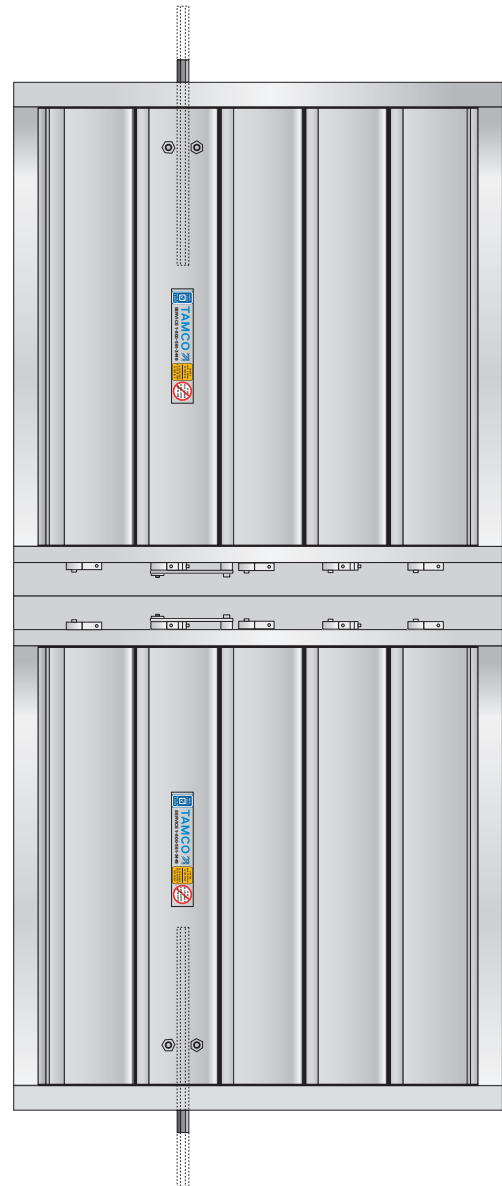

### TAMCO WARRANTY

- TAMCO will honor its warranty if all of the above instructions are adhered to.

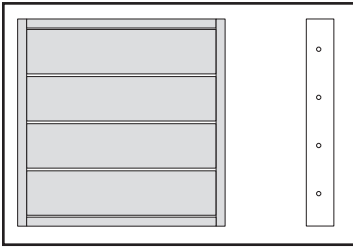

### UNDER- OR OVER-ROTATION OF BLADES

- If light lines are present across the full length of the blade, check that closing torque being applied is neither too little nor too much.
- Under-rotation will not let blade gaskets compress, whereas over-rotation can cause blades to re-separate.

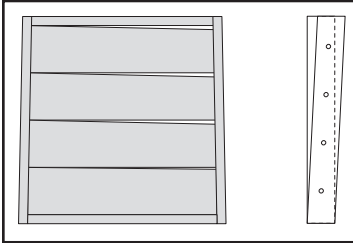

### TWISTED FRAME

- If light lines are observed only along half of the blade length, square up the position of the top frame member, relative to the bottom frame, by pivoting the top frame member either in or out.
- A small movement in one of these two directions could seal light lines, by eliminating frame distortion caused by torque being applied to an unsecured damper.

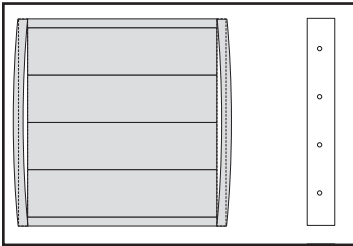

### STRETCHED FRAME

- If light lines are observed between the side frame members and the blade ends of a damper, especially near the center line, verify measurements across the damper at the top, center, and bottom.
- If the measurements should vary by more than  $\frac{1}{16}''$  (2 mm), readjust the side mounting angles to bring the side frame members to the correct dimension, thus matching top and bottom dimensions.
- If light lines disappear, ensure that these matching dimensions are retained when fastening mounting angles during installation.

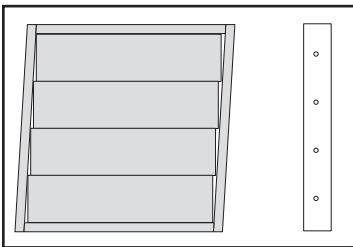

### RACKED FRAME

- If light lines appear only near the top and bottom, on opposite sides of the damper, between the side frame members and the blade ends of a damper, verify square positioning with a tape measure and adjust if required.
- Move the top frame member either left or right to square up the damper. Light lines should disappear.

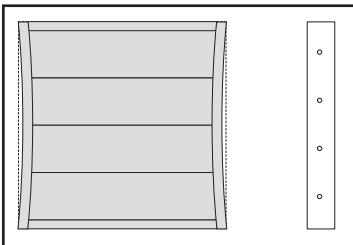

### COMPRESSED FRAME

- If the damper is hard to operate by hand, verify that frame sides are not squeezed in or twisted.
- In either case, bearing life could be sharply reduced.
- Verify that frame sides are parallel by measuring across the damper at the top, center, and bottom.
- Also verify that dimensions on both sides of the damper are equal.

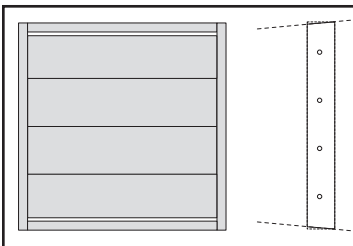

### DISTORTED FRAME

- If light appears only between the last blade and the top or bottom of the damper frame, it may be due to the top or bottom frame member being distorted (twisted) when fastened to the duct work.
- Ensure that the top or bottom frame members are not distorted, by loosening fasteners and shimming the frame, if required.

DO NOT ADJUST LINKAGE MECHANISM. IF PROBLEM STILL EXISTS AFTER VERIFICATION AND CORRECT ACTION, CALL TAMCO CUSTOMER SERVICE

1-800-561-3449

# ALUMINUM CONTROL DAMPER

INSTALLATION GUIDELINES - OPERATION - MAINTENANCE

## SPX ENGINEERED AIR MOVEMENT

80 Lorne Street  
Smiths Falls, ON K7A 5J7, Canada  
800 561 3449  
[tamcodampers.com](http://tamcodampers.com)

TA-IOM-CD-24 | ISSUED 01/2024  
© 2024 SPX Engineered Air Movement | All rights reserved  
In the interest of technological progress, all products are  
subject to design and/or material change without notice.

**SPX**  
TECHNOLOGIES