

TAMCO



HEAVY-DUTY BACKDRAFT DAMPER

INSTALLATION GUIDELINES - OPERATION - MAINTENANCE



READ ENTIRE INSTALLATION GUIDELINE MANUAL BEFORE INSTALLING DAMPERS.



FRONT VIEW



BACK VIEW

TAMCO'S ALL-ALUMINUM BACKDRAFT DAMPERS ARE CONSTRUCTED WITH MAINTENANCE-FREE BEARING AND LINKAGE COMPONENTS.

CAUTION:

- Never use any lubricants, such as grease or silicone, on any backdraft damper parts, including linkage, bearings or hardware. Lubricants attract dust. Accumulated dust particles can abrade and cause damage to damper bearings.
- In applications where the humidity level is unusually elevated, or where there are extremely high levels of dust and dirt particles, TAMCO recommends that the backdraft damper linkage and bearing system should be cleaned once a year. This can be done by blowing away dust using compressed air. If needed, a domestic-strength steam cleaner can be used to loosen dirt, which can then be blown out with compressed air, along with any remaining water droplets.
- **DO NOT ADJUST LINKAGE MECHANISM! IF PROBLEM STILL EXISTS AFTER VERIFICATION AND CORRECT ACTION, CALL TAMCO CUSTOMER SERVICE.**

STORAGE RECOMMENDATIONS:

- Store control dampers indoors to protect from dirt, dust, and weather. The storage space must be clean, dry, and free of elevated humidity or possible condensation. Do not store at temperatures in excess of 100 °F (38 °C).
- The air must be breathable and contaminant-free.
- The dampers must be stored upright. They must not be stacked on top of, or leaning against each other.

Note that all technical information available on TAMCO's website at www.tamcodampers.com supersedes and takes precedence over all information contained within the printed catalog.

CALL TAMCO CUSTOMER SERVICE WITH ANY QUESTIONS CONCERNING TAMCO DAMPERS

1-800-561-3449

VERIFY BEFORE INSTALLATION!

- ✓ Before installing, inspect backdraft damper for possible damage caused in shipping, and that it has not been racked or twisted. Measure the damper from corner to corner to verify that it is square.
- ✓ If minor damage has occurred to frame corners or flanges, correct by bending or hammering back into position. Ensure correct realignment of repair, as bent or twisted frames might not mate properly with mounting angles, or additional backdraft damper sections.
- ✓ Do not install backdraft damper if damage is more than superficial. If uncertain as to extent of damage, or if damper does not operate correctly, **call TAMCO customer service at 1-800-561-3449.**
- ✓ Compare items listed on packing list with materials received to ensure all parts of the shipment are accounted for.

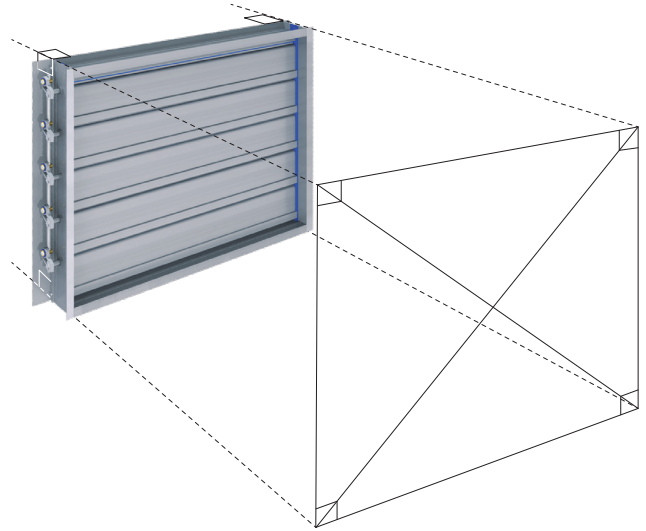

**EXERCISE CAUTION TO ENSURE FINGERS
ARE NOT IN WAY OF MOVING LINKAGE PARTS OR BLADES.**

INSTALLATION GUIDELINES | for TAMCO Heavy-Duty Backdraft Dampers

General Installation Notes

- Backdraft dampers are to be handled and lifted by the frames only. Do not use the blades or linkage to lift backdraft dampers.
- Do not drop, drag or twist.
- Multiple-section assemblies will require sufficient people and appropriate rigging to lift units safely and without causing damage.
- Ensure that the opening or duct work is free of any obstructions and is adequately supported, so that damper performance is not adversely affected.
- The system must support the damper. The damper cannot support the system. Do not use the damper to square up duct. The opening must be plumb, straight, level, square, and sized correctly for the backdraft damper.
- The backdraft damper must not be twisted, compressed or stretched to fit the opening. Once installed, the blades must be free to move without binding. Use shims between the damper frame and the opening to prevent distortion or stretching of the backdraft damper.
- Linkage must remain accessible. When installed in an exhaust application that opens to the outside, linkage will be exposed to weather.
- When installing fasteners (*provided by others*), they should be located so as not to interfere with linkage parts or blade operation.
- Consult engineering plans prior to installation to confirm airflow direction.
- TAMCO recommends that backdraft dampers be installed at a minimum distance of one (1) fan diameter away from the fan, for custom air handler exhaust applications. AMCA 200 and AMCA 201 recommend a distance of one (1) duct diameter for each 1000 fpm in order to achieve uniform air at the backdraft damper. The type of fan and distance allowed between the fan and the damper will determine the air velocity profile the backdraft damper will be subjected to.
- When backdraft dampers are installed in the vertical plane, blades must always be horizontal.
- Series 7600, 7600 WT, 7600 CW, and 7600 CWA Heavy-Duty Backdraft Dampers can be installed in the vertical plane (Airflow Horizontal), or in the horizontal plane (Airflow Up).
- Only Series 7600 CWA Adjustable Counterweighted Heavy-Duty Backdraft Dampers can be installed in the horizontal plane with Airflow Down.

INSTALLED IN DUCT TYPE

- Applies to Series 7600 and 7600 CW only. Series 7600 WT and 7600 CWA cannot be installed in a duct or opening, because the operation of the adjustable external weights or counterweights would be impeded.
- Backdraft damper is manufactured so that finished O.D. is ½" (12.7 mm) smaller than opening width and height dimensions.
- Verify that damper is square.
- Ensure that duct is square and/or large enough to allow damper to be installed square.
- Bottom of frame must sit flat on floor of duct to prevent twisting, sagging, or bowing.
- Secure bottom frame to floor of duct using 90° mounting angles.
- As each mounting angle is installed, verify operation to ensure damper blades move freely and are sealing correctly.
- Caulk all connections/joints between damper frame and duct to minimize installation leakage.

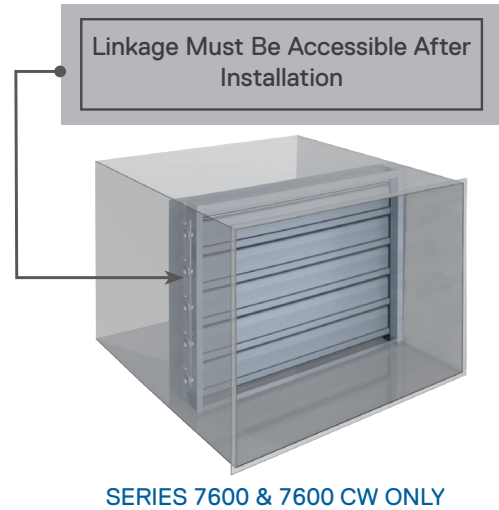

FLANGED TO DUCT TYPE

- Applies to all Heavy-Duty Backdraft Damper Series.
- Front and rear damper flanges are 1" (25.4 mm) larger than duct or opening, around entire perimeter.
- Backdraft damper is manufactured so that finished O.D. is 2" (50.8 mm) greater than opening width and height dimensions.
- Verify that damper is square.
- Do not assume that duct is square. Verify that duct flange is square, flat and, even.
- Fasten damper to duct.
- Operate damper manually to verify free movement of blades and correct sealing.
- Re-verify that damper is square.
- Repeat procedure for other flange, if ducted on both sides.
- Caulk all connections/joints between damper frame and duct to minimize installation leakage.

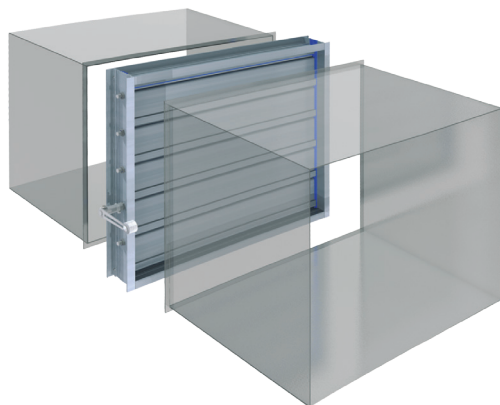
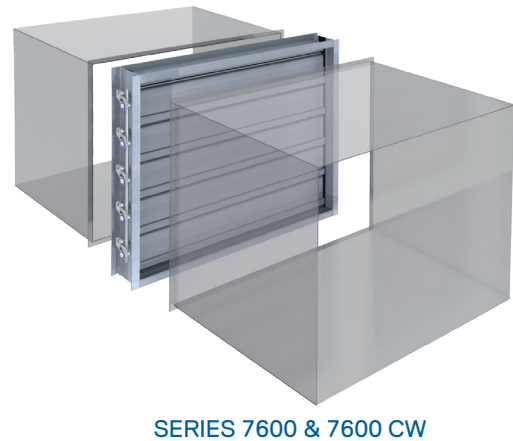

SERIES 7600 WT

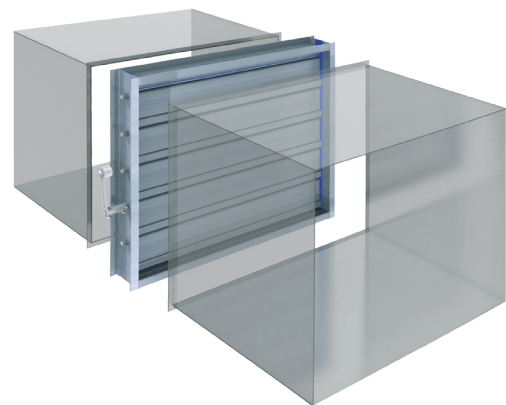

SERIES 7600 CWA

EXTENDED FRONT FLANGE TYPE

- Applies to Series 7600, 7600 CW, and 7600 WT only.
- Series 7600 CWA cannot be installed as Extended Front Flange type, because the extended flange at the front of the damper would impede operation of the adjustable external counterweight.
- Front damper flange is 2" (50.8 mm) larger than duct or opening, around entire perimeter, thereby providing a larger fastening surface.
- Rear damper flange is 1" (25.4 mm) larger than duct or opening, around entire perimeter. *(Note that Extended Front Flange Install Type dampers are not designed so that the rear of the damper may be inserted into an opening, as the side frame members extend to the full height of the front flange.)*
- Backdraft damper is manufactured so that finished O.D. is 4" (101.6 mm) greater than opening width and height dimensions.
- Verify that damper is square.
- Do not assume that opening is square. Verify that opening or duct flange is square, flat, and even.
- Fasten damper to opening surface or duct.
- Operate damper manually to verify free movement of blades and correct sealing.
- Re-verify that damper is square.
- Repeat procedure for other flange, if ducted on both sides.
- Caulk all connections/joints between damper frame and opening or duct to minimize installation leakage.



SERIES 7600 & 7600 CW



SERIES 7600 WT

EXTENDED REAR FLANGE TYPE

- Applies to Series 7600, 7600 CW, and 7600 CWA only.
- Series 7600 WT cannot be installed as Extended Rear Flange type, because the extended flange at the rear of the damper would impede operation of the adjustable external weight.
- Rear damper flange is 2" (50.8 mm) larger than duct or opening, around entire perimeter, thereby providing a larger fastening surface.
- Front damper flange is 1" (25.4 mm) larger than duct or opening, around entire perimeter. *(Note that Extended Rear Flange Install Type dampers are not designed so that the front of the damper may be inserted into an opening, as the side frame members extend to the full height of the rear flange.)*
- Backdraft damper is manufactured so that finished O.D. is 4" (101.6 mm) greater than opening width and height dimensions.
- Verify that damper is square.
- Do not assume that opening is square. Verify that opening or duct flange is square, flat, and even.
- Fasten damper to opening surface or duct.
- Operate damper manually to verify free movement of blades and correct sealing.
- Re-verify that damper is square.
- Repeat procedure for other flange, if ducted on both sides.
- Caulk all connections/joints between damper frame and opening or duct to minimize installation leakage.

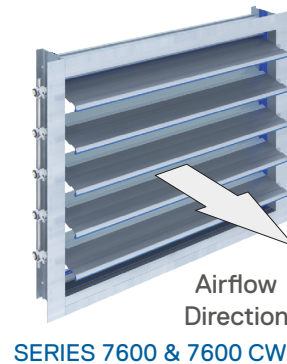

SERIES 7600 & 7600 CW

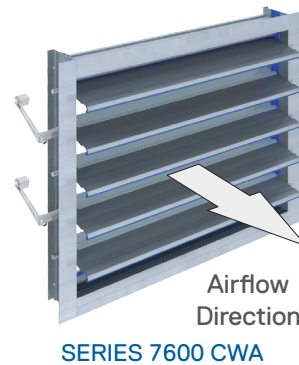

SERIES 7600 CWA

INSTALLING MULTIPLE-SECTION HEAVY-DUTY BACKDRAFT DAMPERS

MULTIPLE SECTIONS CANNOT BE LINKED USING JUMPERS OR JACKSHAFTS

TWO SECTIONS WIDE

- Frame members are designed to overlap and are manufactured with two aligned positioning holes. When heavy-duty backdraft damper sections are correctly positioned, holes will be aligned.
- Bolt alignment fasteners are shipped attached to the offset overlapping frame. *(Alignment holes are not meant to be structural. Bracing may be deemed necessary by installer.)*
- Ensure that both sections are straight, even, and aligned with each other.

ALL ILLUSTRATIONS SHOWN ARE FRONT/TOP END UP DAMPERS

LL = LEFT LINKAGE
RL = RIGHT LINKAGE

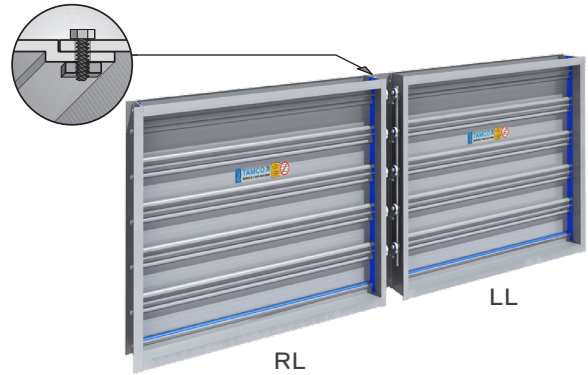

THREE SECTIONS WIDE

- Applies to Series 7600, 7600 CW, and 7600 CWA only. Series 7600 WT cannot exceed two sections wide, because the operation of the external weight on the middle section would be impeded.
- Frame members are designed to overlap and are manufactured with two aligned positioning holes. When heavy-duty backdraft damper sections are correctly positioned, holes will be aligned.
- Bolt alignment fasteners are shipped attached to the offset overlapping frame. *(Alignment holes are not meant to be structural. Bracing may be deemed necessary by installer.)*
- Ensure that all three sections are straight, even, and aligned with each other.

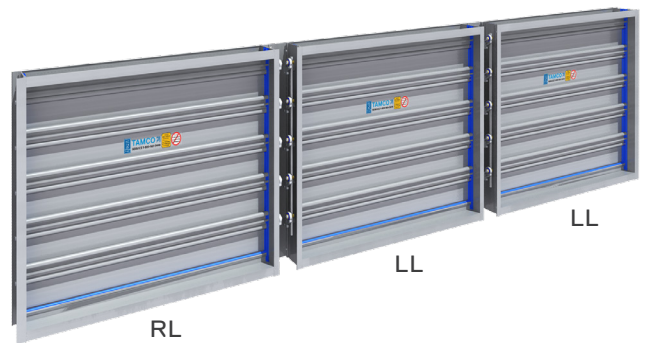

MULTIPLE SECTIONS WIDE BY MULTIPLE SECTIONS HIGH

- Applies to Series 7600, 7600 CW, and 7600 CWA only. Series 7600 WT cannot exceed two sections wide, because the operation of the external weight on the middle sections would be impeded.
- Install bottom tier damper section(s) first.
- Place second level of heavy-duty backdraft damper section(s) on top of bottom section(s), being careful that all sections are properly aligned.
- Install top heavy-duty backdraft damper section(s).
- Slide joiner(s) over frame member(s), where top and bottom section(s) meet(s).
- Using self-drilling screws, fasten joiner to heavy-duty backdraft damper frame member(s) through pre-punched holes in joiner.
- **Caution: Joiner is not designed to be structural. Additional bracing may be required if deemed necessary by installer.**
- Repeat procedure for all additional section tiers.
- Ensure all sections are straight, even, and aligned with each other.

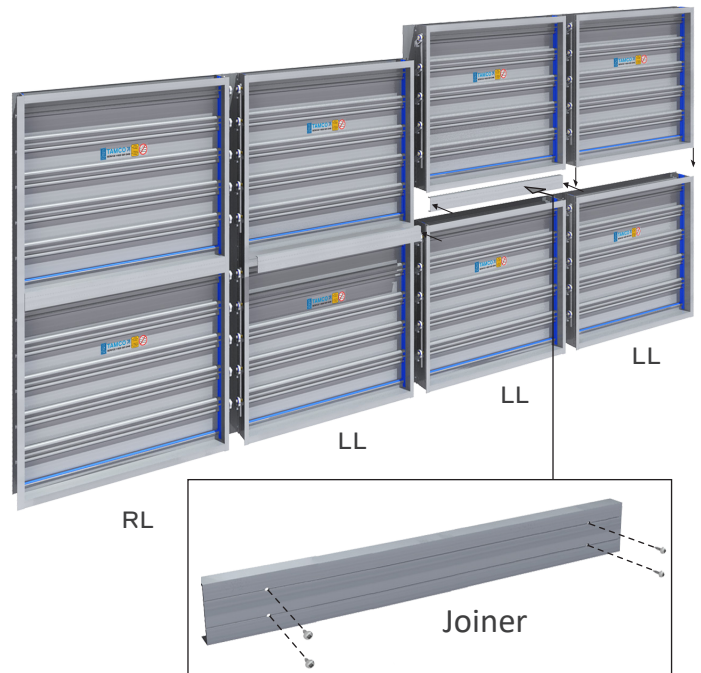

OPTIONAL MULLION END CAPS FOR FLANGED TO DUCT TYPE, MULTIPLE-SECTION DAMPER INSTALLATIONS

- Mullion end caps are provided with all Flanged to Duct install type, multiple-section, heavy-duty backdraft dampers.
- These are required to prevent air flow from passing through open channels. *(Mullion end caps are not intended for use as structural support.)*
- Caulk surfaces between mullion end caps and heavy-duty backdraft damper frame for an airtight seal.
- Mullion end caps are not required for Installed in Duct type nor for Extended Rear Flange install type heavy-duty backdraft dampers. As such they are not provided as standard, but may be ordered as separate parts.



STRUCTURAL DESIGN REQUIREMENTS:

- Intermediate structural support is required to resist applied velocity and pressure loads for backdraft dampers that consist of two or more sections in both height and width. (See illustration to right.)
- Field-supplied tubular structural steel support may be required for large multiple-sectioned backdraft dampers.
- TAMCO Series 7600 and 7600 WT weigh approximately 4.5 lbs/ft² (21.97 kg/m²). Allowance for additional weight must be made for the external weights provided with the Series 7600 WT. The number of external weights used is dependent upon backdraft damper size and installation conditions.
- TAMCO Series 7600 CW and 7600 CW weigh approximately 5 lbs/ft² (24.41 kg/m²). Allowance for additional weight must be made for the external counterweights provided with the Series 7600 CWA. The number of external counterweights used is dependent upon backdraft damper size and installation conditions.

MAXIMUM DEFLECTION:

- The structure providing intermediate support must be designed to resist the highest pressure load, with deflection of less than L/230. This applies whether the pressure load is created by the mechanical system, by wind load, or if the damper is mounted on the exterior of the building.

INTERMEDIATE, FIELD-SUPPLIED, STRUCTURAL SUPPORT IS REQUIRED WHEN INSTALLING IN BOTH THE VERTICAL AND HORIZONTAL PLANES.



GUIDELINES FOR ADJUSTING EXTERNAL WEIGHTS AND COUNTERWEIGHTS

SERIES 7600 WT

- The angle of the external weight crankarm and the number of weights per crankarm will be preset at the factory, to maximize the resistance to opening.
- If installation conditions require field-adjustment to accelerate or delay the opening of the blades, loosen the external crankarm screws and rotate the external weight crankarm(s) until the desired angle is achieved.
- Retighten the external crankarm screws.
- Further adjustment can be made by increasing or reducing the number of weights on the external crankarm(s), or by sliding the weights up or down along the crankarm(s).

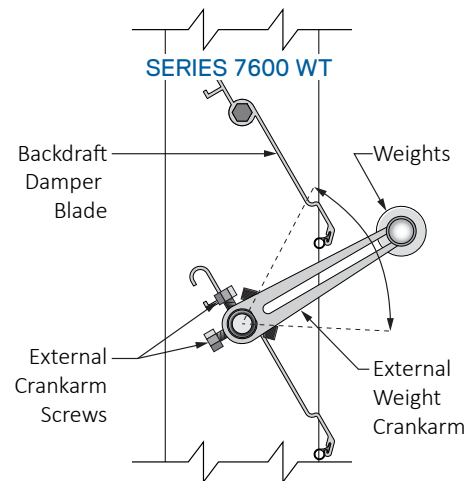

SERIES 7600 CWA

- The angle of the external counterweight crankarm and the number of weights per crankarm will be preset at the factory, to minimize the airflow necessary to open the backdraft damper blades.
- If installation conditions require field-adjustment to accelerate or delay the opening of the blades, loosen the external crankarm screws and rotate the external counterweight crankarm(s) until the desired angle is achieved.
- Retighten the external crankarm screws.
- Further adjustment can be made by increasing or reducing the number of weights on the external crankarm(s), or by sliding the weights up or down along the crankarm(s).

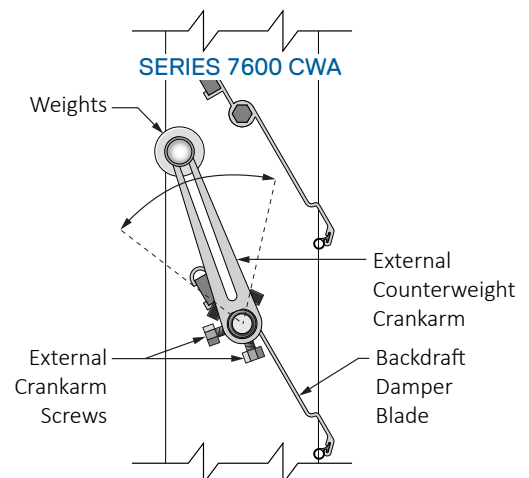

HEAVY-DUTY BACKDRAFT DAMPER

INSTALLATION GUIDELINES - OPERATION - MAINTENANCE

GUIDE FOR TROUBLESHOOTING

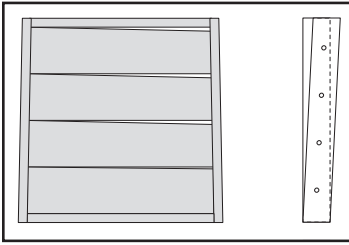

TWISTED FRAME

- If light lines are observed only along half of the blade length, square up the position of the top frame member, relative to the bottom frame, by pivoting the top frame member either in or out.
- A small movement in one of these two directions could seal light lines, by eliminating frame distortion caused by torque being applied to an unsecured damper.

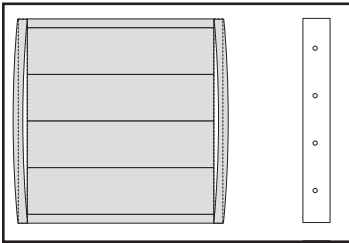

STRETCHED FRAME

- If light lines are observed between the side frame members and the blade ends of a damper, especially near the center line, verify measurements across the damper at the top, center, and bottom.
- If the measurements should vary by more than $\frac{1}{16}$ " (2 mm), readjust the side mounting angles to bring the side frame members to the correct dimension, thus matching top and bottom dimensions.
- If light lines disappear, ensure that these matching dimensions are retained when fastening mounting angles during installation.

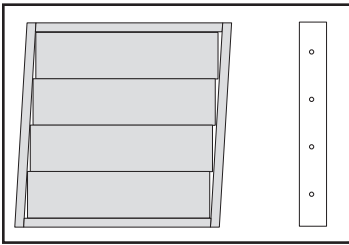

RACKED FRAME

- If light lines appear only near the top and bottom, on opposite sides of the damper, between the side frame members and the blade ends of a damper, verify square positioning with a tape measure and adjust if required.
- Move the top frame member either left or right to square up the damper. Light lines should disappear.

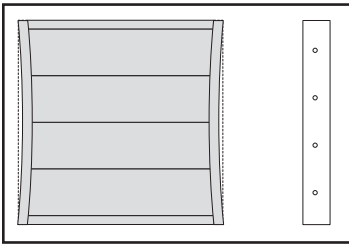

COMPRESSED FRAME

- If the damper is hard to operate by hand, verify that frame sides are not squeezed in or twisted.
- In either case, bearing life could be sharply reduced.
- Verify that frame sides are parallel by measuring across the damper at the top, center, and bottom.
- Also verify that dimensions on both sides of the damper are equal.

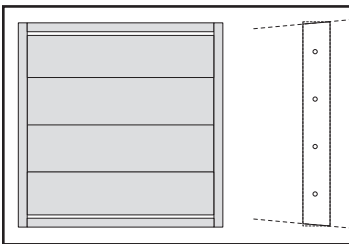

DISTORTED FRAME

- If light appears only between the last blade and the top or bottom of the damper frame, it may be due to the top or bottom frame member being distorted (twisted) when fastened to the duct work.
- Ensure that the top or bottom frame members are not distorted, by loosening fasteners and shimming the frame, if required.

DO NOT ADJUST LINKAGE MECHANISM. IF PROBLEM STILL EXISTS AFTER VERIFICATION AND CORRECT ACTION, CALL TAMCO CUSTOMER SERVICE

1-800-561-3449

SPX ENGINEERED AIR MOVEMENT

80 Lorne Street
Smiths Falls, ON K7A 5J7, Canada
800 561 3449
tamcodampers.com

TA-IOM-HDBD-24 | ISSUED 01/2024
© 2024 SPX Engineered Air Movement | All rights reserved
In the interest of technological progress, all products are subject to design and/or material change without notice.

SPX
TECHNOLOGIES